



ALLIANCE UNIVERSITY

*Private University established in Karnataka State by Act No.34 of year 2010
Recognized by the University Grants Commission (UGC), New Delhi*

BENGALURU



Annual Report 2020-2021

© Alliance University, Bengaluru, India

This is a controlled document. Unauthorized access, copying and replication in any form are expressly prohibited.

This document must not be copied in whole or in parts by any means without the written authorization of the Registrar, Alliance University

All Rights Reserved.

TABLE OF CONTENTS	
Preface	-
Alliance University	1
Vision & Mission	2
Officers of the University	3
Boards, Councils and Committees at Alliance	4
Organization Charts	16
Awards, Accolades and Accreditations	20
Research at Alliance	22
Conferences, Seminars & Workshops	28
Human Resource Department	33
Student Enrollment	36
Library Resources	41
Office of International Affairs	47
Office of Career Advancement & Networking	56
Alliance Alumni Association	70
Information Technology Services	75
Student Support Services	83
Office of Registrar	101
Convocation 2021	108
Academic Units	116
New Academic Departments	139
Research Policy	140
Infrastructure	141

PREFACE

Alliance University, a Private University established in Karnataka by the State Act No.34 of year 2010. The University is jointly recognized by the University Grants Commission (UGC) and the All India Council for Technical Education (AICTE), New Delhi. Alliance Education, defined by excellence in the areas of Business Administration, Engineering, Legal studies and guided by the core values of the University, has shaped the lives of over 20,000 very successful alumni across the globe.

Alliance University has been recognized as a significant academic institution of the country through its multi-dimensional curricular and co-curricular activities. Several industry associations, media and public institutions have conferred awards on Alliance University for its outstanding achievements over the years, since its inception.

In addition to the existing academic units, the University aims to establish more units in years to come, to cater to the ever-changing needs of the industry and meet diverse student aspirations by forging strategic partnerships with academia and the industry. Alliance University, guided by the boards at several levels, will continue to maintain its values of:

- Integrity
- Respect for the Individual
- Transparency
- Financial Prudence
- Passion for Quality and Excellence

The University shall focus on ensuring community literacy, enhanced critical thinking among the student fraternity coupled with a humanistic approach and a scientific bent of mind. The University is confident that it would receive the required support from all its stakeholders to make this possible and become one of the greatest Universities in the world.

Dr. Nivedita Mishra
Registrar – Alliance University

Bengaluru

ALLIANCE UNIVERSITY

Alliance University is a renowned university of higher learning located on an extensive state-of-the-art campus in Bengaluru offering a variety of degree courses. The University has baccalaureate concentrations, postgraduate offerings, doctoral degree programs and several professional certificate programs.

Alliance University, a Private University established in Karnataka by the State Act No.34 of year 2010. The University is jointly recognized by the University Grants Commission (UGC) and the All India Council for Technical Education (AICTE), New Delhi.

Alliance University aspires to be among the best universities in the world by the year 2025 through a series of strategically crafted moves, precisely calibrated action plans and an unwavering commitment to the pursuit of excellence.

While its oldest professional school—Alliance School of Business—is consistently ranked among the top ten private business schools in India by various ranking agencies, the University having already established Alliance College of Engineering and Design; Alliance School of Law; and Alliance Ascent College, Alliance School of Applied Mathematics, Alliance School of Liberal Arts, Alliance School of Digital Technology, Department of Language & Literature, Department of Economics and Department of Science, is in the process of establishing many other prominent academic units, *viz.*, Alliance College of Arts and Humanities; Alliance College of Science; Alliance College of Medicine and Dentistry; Alliance College of Education and Human Services; Alliance School of Health Sciences; and Alliance College of Media and Communications.

The ambience and serenity of a world-class infrastructure housed in a 'green' campus; faculty who have proven themselves in their respective fields by providing an excellent blend of rigor and relevance in their teaching; staff who are ever ready to reach out; robust industry interactions; research aimed at solving problems of the real world; a plethora of international collaborative arrangements; outreach activities that touch the lives of a wide cross section of society; and an exemplary track record in career counseling and placement facilitation—all combine to provide a rare synergy that transcends artificial barriers and enables students to follow their hearts with passion and confidence.

VISION & MISSION

Vision

To be a world-class university that nurtures talent and catalytically transforms the lives of millions through excellence in teaching, research, service and community development. To uphold a commitment to shaping lives through scholarly teaching and learning, and that which contributes to an equitable and holistic transformation of society at large.

Mission



To create and sustain a community of lifelong learners in an environment that emphasizes literacy, critical thinking and humanistic and scientific inquiry.

The University shall provide a dynamic, challenging and ethical environment for pursuing high quality teaching, research, learning and service across all areas of the University, where students, faculty and other key constituents can interact, collaborate, and partner with the global community for the creation and dissemination of knowledge and transform the lives of people through innovation and excellence in higher education.

The University shall

- Pursue excellence in teaching, learning and scholarship.
- Prepare students for leadership through enlightened learning partnerships with faculty mentors and the community.
- Support faculty and other scholars in pursuing world-class research: clinical, theoretical, empirical, experiential and foster creative endeavor.
- Promote and preserve academic freedom, diversity, equality, harmony and justice.
- Develop mastery of disciplines and professions and instill confidence among its key constituents in their application for a future of meaningful pursuits and productive work in the service of humanity.
- Channelize faculty and student talent for professionally-related service to the university, the community and society at large

OFFICERS OF THE UNIVERSITY

<p>Visitor His Excellency The Governor of Karnataka State</p>	 Hon'ble Shri Thaawarchand Gehlot
<p>Pro – Visitor Honorable Minister for Higher Education Government of Karnataka</p>	 Dr. C. N. Ashwath Narayan
<p>Chancellor</p>	<p>Prof. Premanand shetty</p>
<p>Pro – Chancellor</p>	<p>Mr. Abhay G. Chebbi</p>
<p>Vice – Chancellor</p>	<p>Dr. Anubha Singh</p>
<p>Pro Vice – Chancellors</p>	<p>Dr. Ray Titus Pro Vice-Chancellor(Academics & Research)</p> <p>Mr. Prakash S. Budur Pro Vice-Chancellor (Banking, Finance, Development & New Initiatives)</p>
<p>Deans of Faculties</p>	<p>Dr. Ray Titus Alliance School of Business</p> <p>Dr. Reeba Korah Alliance School of Business</p> <p>Dr. Kiran Gardner Alliance School of Business</p>
<p>The Registrar</p>	<p>Dr. Nivedita Mishra</p>
<p>The Finance Officer</p>	<p>Mr. Kadahalli Basavaraj Veerappa</p>

Board of Governors

Prof. Premanand Shetty Chancellor	Chairperson
Dr. Anubha Singh Vice-Chancellor	Member
The Principal Secretary / Secretary to the Government Department of Higher Education, MS Building Dr. B R Ambedkar Veedi, Bengaluru – 560001	Member
An eminent educationist and academician, preferably a woman from the panel of names to be recommended by the Visitor The University has requested for nominee vide letter no. AU/OC-BOG/2016-189, dated June 17, 2016	Member
Three persons nominated by the Sponsoring Body	
Mr. Abhay Chebbi, Pro Chancellor, Alliance University	Member
Mrs. Shaila G. Chebbi, Director, Alliance Business School	Member
Mr. Prakash S. Budur, Pro Vice-Chancellor (Banking, Finance, Development & New Initiatives), Alliance University	Member
An eminent educationist nominated by UGC * As per reference to UGC letter no. F. 13-4/2015 (CPP –II), dated April 8, 2016, there shall not be any nominee from UGC.	
The Registrar and Pro Vice–Chancellor will be non–voting invitees on the Board of Governors	

Board of Management

Dr. Anubha Singh Vice-Chancellor	Chairperson
Dr. Ray Titus Pro Vice-Chancellor (Academics and Research)	Member
Dr. Nivedita Mishra Registrar	Secretary

Nominees recommended by the Sponsoring Body

Prof. Mihir Dash Associate Professor & Area Chair - General Management Alliance School of Business	Member
Dr. Vivekanand G Professor & Dean - Research	Member

Nominees recommended by the Vice-Chancellor

Dr. Kiran Gardner Dean – Alliance School of Law	Member
Dr. Reeba Korah Associate Dean – Alliance College of Engineering and Design	Member

Academic Council

Dr. Anubha Singh Vice-Chancellor	Chairperson
Dr. Ray Titus Pro Vice-Chancellor (Academics and Research)	Member
Dr. Nivedita Mishra Registrar	Secretary

Nominees recommended by the Vice-Chancellor

Dean – Research	Member
Dean - Alliance College of Engineering & Design	Member
Dean - Alliance School of Law	Member

Research Council

Dr. Anubha Singh Vice-Chancellor	Chairperson
Dr. Ray Titus Pro Vice-Chancellor (Academics and Research)	Member
Dean Alliance School of Business	Member
Dean Alliance College of Engineering and Design	Member
Dean Alliance School of Law	Member
Dean – Research Alliance University	Secretary
Dr. Selvarani R Program Director Doctoral Program, ACED	Member
Dr. Pratima Verma Professor - Alliance School of Business	Member

Finance Committee

Mr. Abhay Chebbi Pro Chancellor	Chairperson
Dr. Anubha Singh Vice-Chancellor	Member
Mr. Prakash Budur Pro Vice Chancellor (Banking, Finance, Development & New Initiatives) Alliance University, Nominee of the Sponsoring Body	Member
Dr. Nivedita Mishra Registrar	Member
Mr. Kadhalli Basavaraj Veerappa Finance Officer	Secretary

Fee Regulation Committee

Prof. Premanand Shetty Chancellor	Chairperson
Principal Secretary to the Government in-charge of Higher Education or his nominee	Member
Three other members nominated by the Chairman	
Mr. Abhay Chebbi Pro Chancellor	Member
Mr. Prakash S. Budur Pro Vice-Chancellor (Banking, Finance, Development & New Initiatives)	Member
Mr. Kadahalli Basavaraj Veerappa Finance Officer	Secretary

BOARD OF STUDIES**Faculty of Management**

Dr. Ray Titus Pro Vice Chancellor & Dean (Academics and Research)	Chairperson
Dr. Ramanna Shetty Professor & Director, Alliance Ascent College	Member
Dr. Sajan Mathew Professor & Registrar [Examination & Evaluation]	Member
Dr. Vivekanand G Professor Dean - Research & Area Chair - OB & HR	Member
Prof. Mihir Dash Associate Professor & Area Chair General Management	Member
Dr. George Easaw Professor & Area Chair, Operations Management	Member
Dr. Ajeet Sharma Associate Professor & Area Chair, Marketing	Member
Dr. Arunabhas Bose Assistant Professor & Program Director EPGDM	Member
Dr. Renu Rajani Vice President – Technology AMS, Bank of America	Member

Mr. Shiva Tanuku VP-Digital Transformation, AI & Analytics, Strategic Initiatives Accenture	Member
Mr. Mike Murali Director Marketing & Chief Fun Officer, Capgemini	Member
Mr. Surya Prakash Mohapatra Global Head – Talent Transformation & Global Practice Head- Learning Services, Wipro	Member
Mr. Ashish Jalan Director, Head of Global Operations and Training Envision Financial Systems, Inc.	Member
Mr. Shreyas Kumar Director and CFO Carl Zeiss India	Member
Mr. Ritesh Arya Director of Finance Oracle	Member
Mr. Ajay Agrawal Senior Vice President Global Head of Analytics and Artificial Intelligence Happiest Minds Technologies	Member
Dr. Kapil Arora Professor & Area Chair - Finance	Secretary

Faculty of Engineering and Design

Dr. Reeba Korah Professor & Interim Dean	Chairperson
Dr. Vipin Prasad Professor & HOD, Basic Sciences	Member
Dr. Chitra Kiran N Professor & HOD - Electronics & Communication Engineering	Member
Dr. Sheila Mahapatra Associate Professor & HOD - Electrical & Electronics Engineering	Member
Dr. Shekhar R Professor & HOD - Computer Science & Engineering	Member
Dr. Mahantesh N.B Associate Professor & HOD - Civil Engineering	Member
Prof. Rathnakar Achary Associate Professor & Deputy HOD - Information Technology	Member
Prof. Velmurugarajan. K Professor & HOD - Aerospace Engineering	Member
Mr. Jagadeesh Kumar Country Head - India - Genesys Aerosystems	Member
Mr. Mahesh Kolar Executive Director: Digital & Emerging Technologies Practice Leader – Consulting, Ernst & Young	Member
Dr. U. Chandrasekhar Program Director – AddWize, Wipro 3D	Member
Mr. Ajay Agrawal Senior Vice President Global Head of Analytics and Artificial Intelligence - Happiest Minds Technologies	Member
Dr. Sridhar MK Retired Scientist - Hindustan Aeronautics Limited	Member
Dr. Raghuprasad Retired Professor Indian Institute of Science (IISc)	Member
Dr. Girish B.M Professor & HOD - Mechanical Engineering	Secretary

Faculty of Law

Dr. Kiran Dennis Gardner Professor & Dean, Alliance School of Law	Chairperson
Dr. B S Reddy Professor	Member
Dr. Aisha Sharfi Associate Professor	Member
Dr. Rashmi K.S. Assistant Professor	Member
Dr. Heena Ghanshyam Patoli Assistant Professor	Member
Prof. Rahul Mishra. Assistant Professor	Member
Dr. Avanish Bhai Patel Assistant Professor	Member
Dr. Sumant Kumar Assistant Professor	Member
Dr. Vineetha Sivakumar Assistant Professor	Member
Dr. Upankar Chutia Assistant Professor	Member
Prof. Abhishek Sarma Assistant Professor	Member
Prof. Yamini Chandra Prabha Assistant Professor	Member
Dr. V Nagaraj Professor, National Law School of India University, Bangalore	Member
Mr. Thaj Mathew Director Legal, Honeywell Technology Solutions	Member
Dr. Devaiah N.G. Assistant Professor	Secretary

Board of Examinations

Dr. Anubha Singh Acting Vice-Chancellor & Pro Vice-Chancellor (Academics, Research & Strategy)	Chairperson
Mr. Madhu Sudan Mishra Registrar – Examination and Evaluations	Member
Dr. Sajan Mathew Registrar (Examination & Evaluation)	Member
Dr. Ray Titus Professor & Dean, Alliance School of Business	Member
Dr. Reeba Korah Professor & Interim Dean, Alliance College of Engineering & Design	Member
Dr. Kiran Dennis Gardner Professor & Dean, Alliance School of Law	Member
Dr. Sunil Kumar Deputy Registrar (Examination & Evaluations)	Member
Dr. Nivedita Mishra Deputy Registrar – Examination and Evaluation	Secretary

Examination Grievance Committee (Malpractice)

Prof. Ramanna Shetty Professor and Director, Alliance Ascent College	Chairperson
Dr. Devaiah N.G. Assistant Professor, Alliance School of Law	Member
Prof. Rahul Mishra Assistant Professor, Alliance School of Law	Member
Dr. Girish B.M. Professor and HoD - Mechanical Engineering, Alliance College of Engineering & Design	Member
Dr. Rathnakar Achary Associate Professor & HOD - Information Technology, Alliance College of Engineering & Design	Member
Dr. Nivedita Mishra Registrar	Member
Mr. M. S. Ananth Assistant Registrar (Examinations and Evaluation)	Secretary

Library Advisory Committee

Dr. George Easaw Professor & Area Chair- Operations Management, Alliance School of Business	Chairperson
Dr. Femina Syed Associate Professor, Alliance School of Business	Member
Dr. Rashmi K S Assistant Professor, Alliance School of Law	Member
Prof. Heena Ghanshyam Patoli Assistant Professor, Alliance School of Law	Member
Prof. T Sridhar Professor, Alliance College of Engineering & Design	Member
Prof. Manjunath S.V. Assistant Professor, Alliance College of Engineering & Design	Member
Dr. Prakash I.N. Librarian	Secretary

Food Committee

Mrs. Shaila Chebbi Director, Administration Alliance University	Chairperson
Mr. Kiran K Gautama Havaladar Deputy Registrar, Office of the Registrar	Member
Dr. George Easaw Professor & Area Chair, Operations Management Alliance School of Business	Member
Prof. Sunil Kumar Professor, Alliance School of Business Deputy Registrar (Examinations and Evaluation)	Member
Dr. Sheila Mahapatra Associate Professor & HOD, EEE Alliance College of Engineering & Design	Member
Mr. Chitradeep Chakraborty Senior Manager, Student Support Services	Secretary

Grievance Redressal Committee

Dr. Nivedita Mishra Registrar	Chairperson
Senior Administrator Nominated by the Chancellor	
Mr. Santosh Kawari Chief Information Officer(CIO)	Member
Mr. Rama Rao K Manager HR - Human Resource Policy and Regulations Alliance University	Secretary

Equivalence Committee

Dr. Anubha Singh Vice-Chancellor	Chairperson
Dr. Ray Titus Pro Vice-Chancellor & Dean, Alliance School of Business	Member
Dr. Sajan Mathew Registrar, Examination & Evaluation	Member
Dr. Reeba Korah Professor & Interim Dean - Alliance College of Engineering & Design	Member
Dr. Kiran Gardner Professor & Dean- Alliance School of Law	Member
Dr. Nivedita Mishra Registrar	Member
Dr. Ramanna Shetty Professor & Director - Alliance Ascent College	Member
Professor & Interim Dean Alliance School of Law	Member
Dr. Selvarani R Professor and Program Director – Doctoral Program	Member
Mr. Rajen Chatterjee Director - International Affairs	Member
Dr. Sunil Kumar Deputy-Registrar (Examinations and Evaluation)	Secretary
Mr. Ravi Kiran V Deputy-Registrar (Examinations and Evaluation)	Member

Equal Opportunity Cell

Prof. Nayan Tara Acharya Assistant Professor, Alliance School of Business	Chairperson
Dr. K. Riyaz Ahmed Assistant Professor, Alliance School of Business	Member
Dr. Thangajam Ravichandra Singh Assistant Professor & Deputy Director - Alliance Ascent College	Member
Prof. Sunil Kumar L Assistant Professor, Alliance School of Law	Member
Prof. Arun Kumar BP Assistant Professor, Alliance College of Engineering & Design	Member
Mr. Rudreshwaraiah H M Assistant Director, Department of Student Support Services	Secretary

Alliance Centre for Women Empowerment

Dr. Nivedita Mishra Registrar	Chairperson
Mrs. Shaila Chebbi Director - Administration	Member
Dr. Bharathi S Assistant Professor Associate Dean – Centre for Post-Graduate Legal Studies – Alliance School of Law	Member
Dr. Radha R Assistant Professor – Computer Science Alliance College Engineering & Design	Member
Dr. Pratima Verma Professor – OB & HR Alliance School of Business	Member
Ms. Angel Susan Jose Executive – HR	Secretary

Disciplinary Committee (Non- Academic)

Dr. Sanjeev S. Padashetty Professor and Deputy Registrar (Admin) Office of the Registrar	Chairperson
Mr. Kiran K Gautama Havaladar Deputy Registrar, (Admin) Office of the Registrar	Member
Professor of the concerned School	Member
Deputy Director/ Assistant Director- Student services	Secretary

Disciplinary Committee (Academic)

Dr. Sanjeev S. Padashetty Professor and Deputy Registrar (Admin)	Chairperson
Dr. Sajan Mathew Professor and Registrar (Examination and Evaluations)	Member
Dean/ Associate Dean/ Assistant Dean of the concerned School	Member
Professor of the concerned School	Member
Deputy Director/ Assistant Director- Student services	Secretary

ANNUAL REPORT 2020-2021

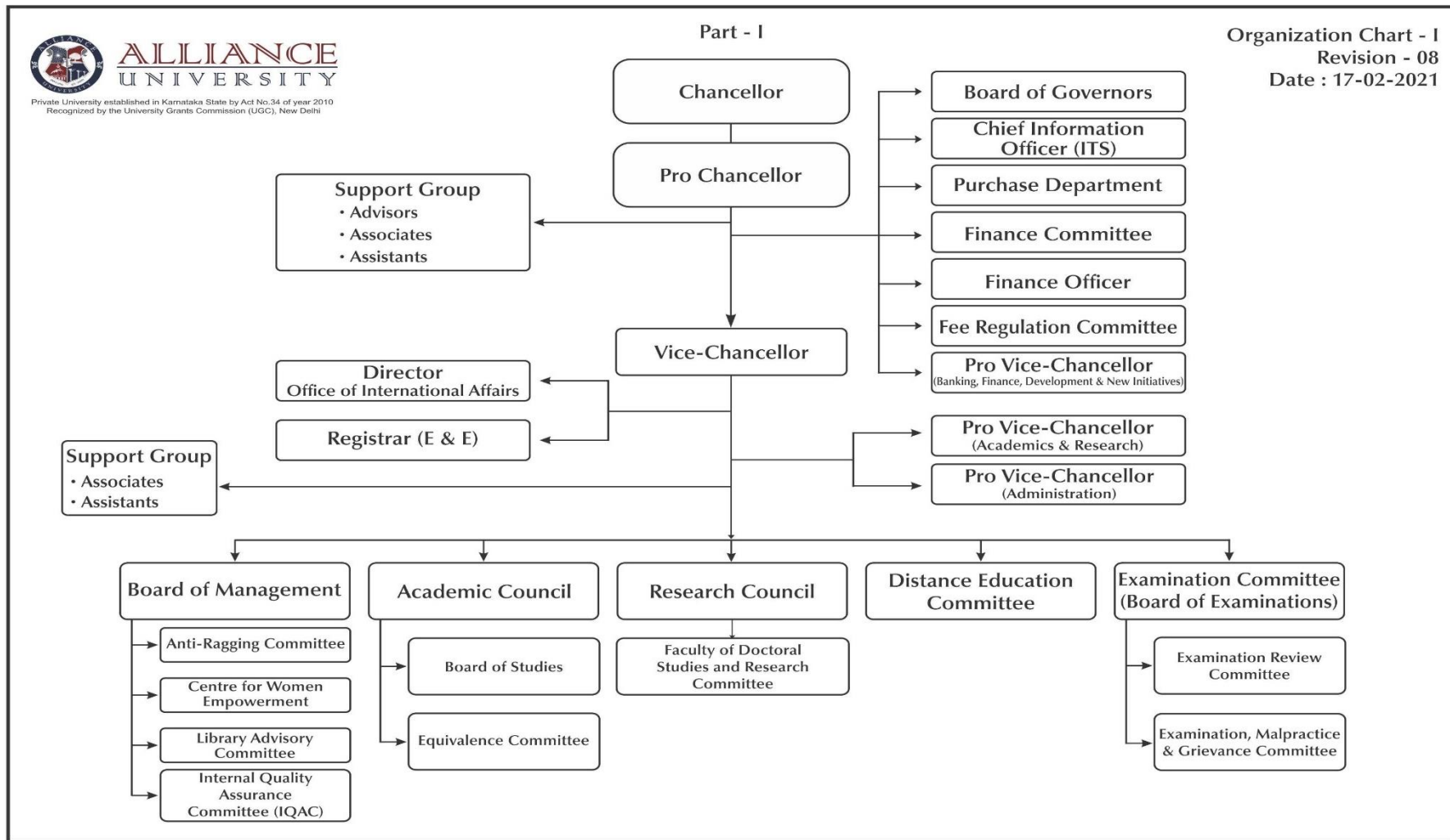

ANNUAL REPORT 2020-2021



Organization Chart - I
Revision - 08
Date : 17-02-2021

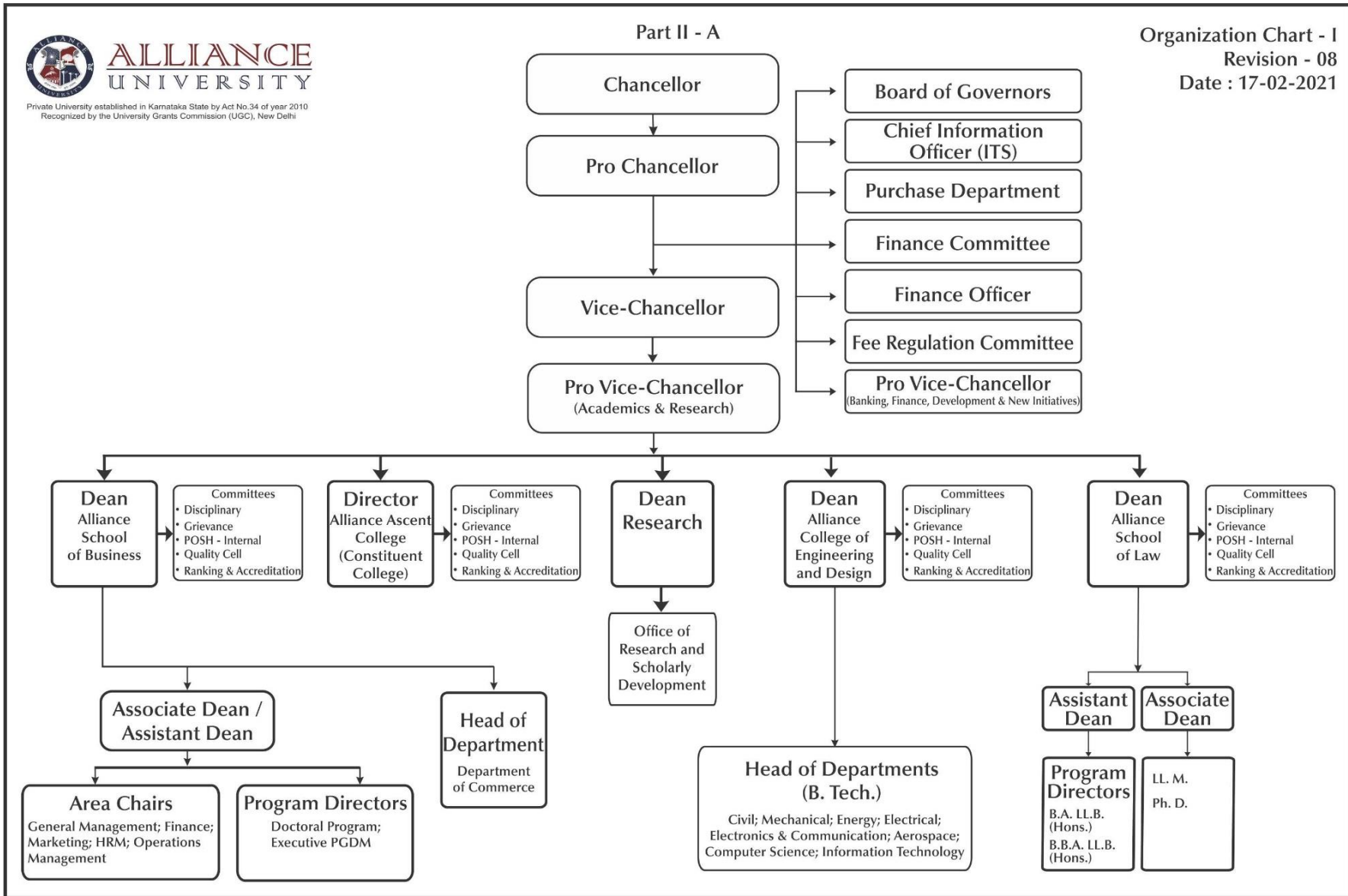

ANNUAL REPORT 2020-2021



Part II - B

Organization Chart - II
Revision - 08
Date : 17-02-2021

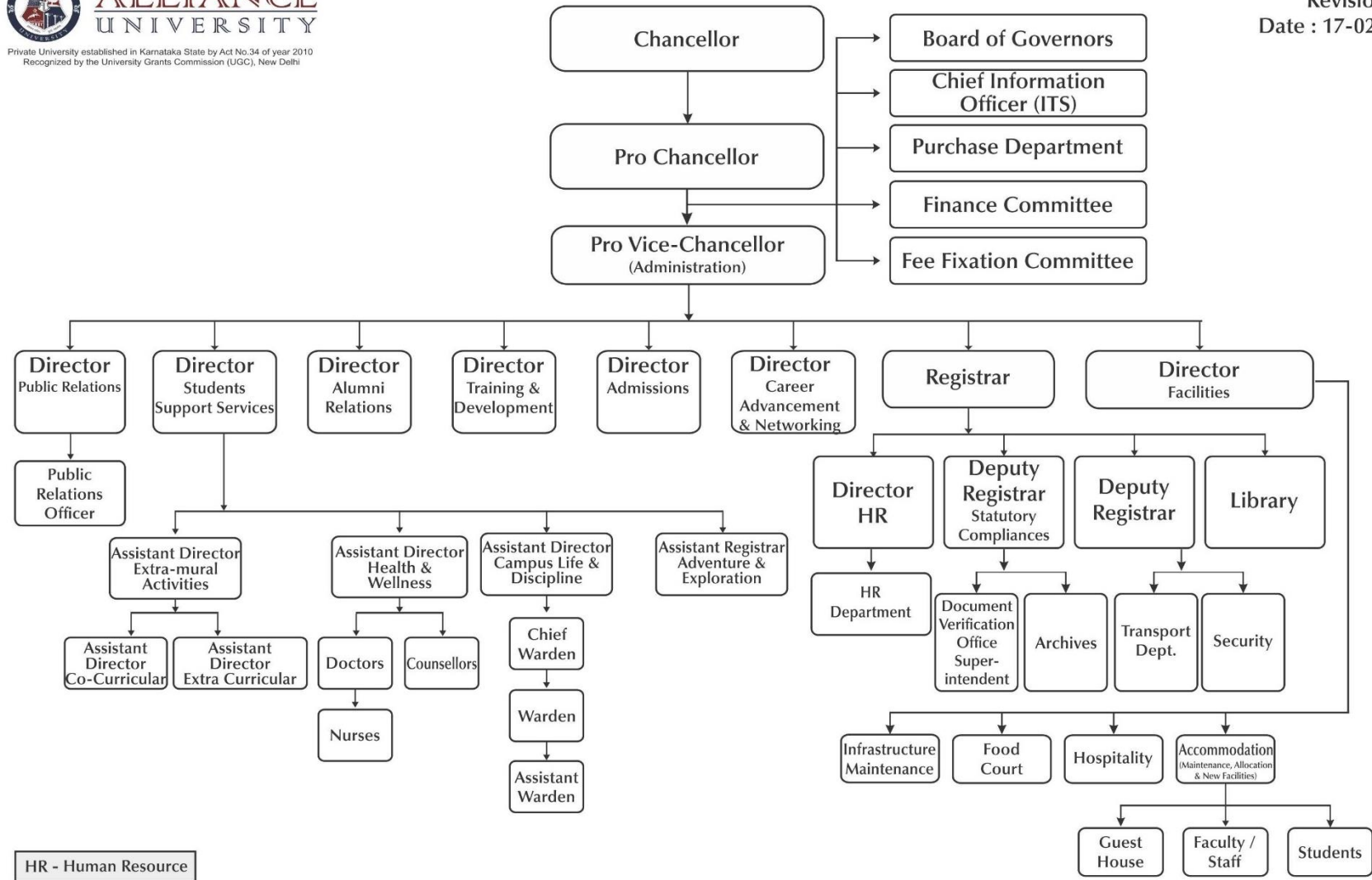



Part II - C

Organization Chart - III
Revision - 08
Date : 17-02-2021

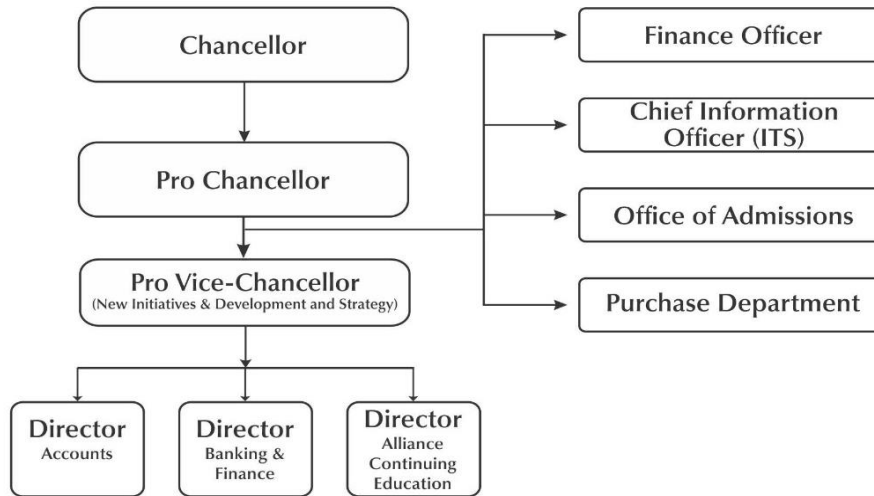

AWARDS, ACCOLADES AND ACCREDITATIONS

The University, in its pursuit of excellence in quality education, continues to make an impact by being consistently ranked high across various categories and strengthens its value proposition to students through accreditations from both national and international bodies. The year witnessed Alliance University being awarded for academic digitization, heralding the University's preparedness to offer hybrid learning among many other recognitions.



#7 Best Private University
India Today, June 2018



#10 Best B-School in India offering
Global Business Courses, 2018



#39 Among Management
Institutes (including IIMs)



#3 Best B-School under
Private University



Alliance University is a member of
The Association to Advance Collegiate
Schools of Business (AACSB), USA



Alliance School of Business is accredited
by International Accreditation Council for
Business Education (IACBE), USA



#11 Law School for
Outstanding Excellence
CSR-GHRDC Law School Survey 2018



#16 Best Private
Law School in India



Alliance School of Law is approved by
Bar Council of India (BCI), New Delhi



Ranked in AAA Category by
Careers 360 Magazine, 2019



Alliance University is an
Academic Affiliate of The Institute of
Engineering and Technology, [IET] UK



Most Preferred Private University of the Year – South
Most Preferred B-School Providing Global Exposure
February 2020



Alliance University was appraised
with Diamond Rating for Teaching,
Employability and Facilities in the
QS I•GAUGE rating system



Alliance University
Awarded the QS I•GAUGE
E-Learning Excellence for
Academic Digitisation in 2020



"Alliance University has featured in
"Great Indian Institutes" Forbes India Marquee 2018
- a special Marquee Edition in association with
SkillTree Knowledge Consortium and Great Place To Study".



Best University in Building
Industry Academia Interface at
National Education Awards, 2018

NIRF Rankings 2021

The Ministry of Human Resource Development has announced the India Rankings for 2021, based on the National Institutional Ranking Framework (NIRF). The e-version of the rankings has been published by Hon'ble Education Minister Shri Dharmendra Pradhan.

We are delighted to report that Alliance University has been ranked as:

- 60th among management institutions, including IIMs

The University is slated to grow leaps and bounds with time and this would require focused attention, contemporary strategies and collective unison to move past our own laurels and create new benchmarks.



#60 Management Institution
in India (including IIMs), 2021

RESEARCH AT ALLIANCE

Research plays a critical role in both knowledge inventory and transformation at various levels in any growing economy. At Alliance, we firmly believe in the importance of research and hence our conscious step towards setting up various centers for research. This predominantly is to bring together like-minded individuals from various disciplines, industries and backgrounds to amalgamate on focused research in various areas. This endeavor would generate new ideas and promote path-breaking solutions to pertinent problems across industry verticals, academia and the society at large.

Center for Academic Research would focus on driving academically rigorous research through our post-graduate programs especially the doctoral program.

Center for Applied Research would focus on engaging with the business and non-business entities and collaborating with them for arriving at research-based solutions to meet their current and future work-related requirements.

Center for Social Impact and Research would focus on engaging with the society at large to offer research-based holistic and sustainable solutions to some of the persisting environmental and societal issues.

The year 2020 also witnessed the emergence of three new **Centers of Excellence** to enhance research dexterity at the University:

Alliance Center for Leadership and Public Policy

Alliance Center for Leadership and Public Policy aims to create and support an environment of rigorous, systematic and scientific research; implement cutting-edge professional development programs; develop leadership competencies; improve leadership practice and enhance community robustness through law, justice and human rights.

The center shall:

- Undertake research on contemporary issues of social development, global justice, economic studies, law and justice reforms and futurist studies
- Create innovative leadership, communication and organizational development intervention programs for students and corporates
- Strengthen student knowledge and capacities by honing their leadership abilities through organized workshops, seminars and lectures
- Share knowledge gained through research and advocacy for the benefit of the society
- Synergize public policy with law, justice and human rights

Alliance Center for Media Studies and Research

Alliance Center for Media Studies and Research aims to impart quality education and offer certificate programs in the area of media production and journalism. The genesis of the Centre is driven by the fact that media in contemporary society has become the ubiquitous phenomenon that not only provides entertainment and information but also touches every facet of our daily life through social media and other user interfaces of varied types.

The center shall:

- Run courses and certificate programs in media production and journalism
- Provide skill-based training programs
- Carry out research that addresses contemporary issues of relevance encompassing media and its role in the fields of business, law, and technology
- Develop media labs equipped with media production facilities and other cutting-edge technologies for carrying out training and research activities

As part of these centers, several workshops, seminars, and webinars were organized.

Alliance Management Studies International Conference (AMSICON)

Theme: Social Challenges and Business Responses

Overview:

With the dynamic transformation in the socio-cultural-ethico-political environment, the responses and responsibilities of businesses call for a close critical examination. Amidst a greater focus on the meta-business social responsibilities on one hand and a constant digital/technical evolution on the other, companies are in the process of constantly rethinking their business dynamics and operations. Further, with both a macro and a micro, an objective and a subjective shift in the social practices, the determining factors of a business are going through a sea change. Local or global, national or multinational, such challenges range from environmental sensibilities to anti-consumption treatises, sustainable business paradigms to issues of inclusivity and gender parity, posthumanist anthropomorphic inclusion of AI to emerging trends in ethico-business analytics. No wonder, such transformative practices call for a leader who is a visionary that encompasses the ethos of a 'race, milieu and moment'.

AMSICON 2021 is meant not only to discourse prognostically on such changes but collectively to find solutions for a better world where businesses, culture, and society may harmoniously interact.

AMSICON

ALLIANCE UNIVERSITY
Private University established in Karnataka State by Act No. 34 of year 2010
 Recognized by the University Grants Commission (UGC), New Delhi
BENGALURU

**ALLIANCE MANAGEMENT STUDIES
 INTERNATIONAL CONFERENCE 2021 (AMSICON)**

**THEME: SOCIAL CHALLENGES
 AND BUSINESS RESPONSES**

**CONFERENCE DATES:
 JANUARY 29-30, 2021**

KEYNOTE SPEAKERS

Prof. Dr. Pia A. Albinsson
 Prof. of Marketing
 Appalachian State University,
 USA

Prof. Dr. Markus A. Launer
 Prof. of General Business
 Administration
 Ostfalia University, Germany

Dr. Frithiof Svenson
 Researcher, Faculty of
 Trade and Social Work
 Ostfalia University, Germany

Prof. Lee Edwards
 Associate Professor
 London School of Economics
 and Political Science, UK

**Prof. Alexandra Ganglmair
 Wooliscroft**
 Senior Lecturer
 Massey University Auckland,
 New Zealand

Prof. Dr. Ben Wooliscroft
 Associate Dean Research
 Auckland University of
 Technology, Auckland,
 New Zealand

Prof. Dr. Gulnur Tumbat
 Professor
 Lam Family College of Business,
 San Francisco College
 of Business, USA

Prof. Laurel Steinfield
 Assistant Professor
 Bentley University, USA

TRACKS

MARKETING

**ECONOMICS
 & FINANCE**

**ORGANIZATIONAL
 BEHAVIOR &
 HUMAN RESOURCE**

**LEADERSHIP &
 BUSINESS DECISIONS**

**OPERATIONS,
 IT AND SYSTEMS**

**COMMUNICATION,
 GENDER AND
 CULTURE STUDIES**

National Conference on Law and Social Transformation - 2021(NCLS-2021)

Theme: Law and Social transformation

The thought of organizing a National Conference on Law and Social transformation [NCLS-2021] took roots with the desire to pay homage to legal legendary Mr. Nani Palkhivala, who was a champion of civil liberties, a far-sighted economic thinker and a par-excellence lawyer. The aim is to celebrate his birth centenary, commemorating his scholarly contribution towards "the basic structure" doctrine. Discussing all the facets of his charismatic personality will surely inspire and motivate students, teachers and the young legal professionals to follow his example of hard work, self-improvement and dedication towards the profession.

Law does not work in isolation but works in society. Law not only is an effective instrument for social change, but it also leads to peaceful social transformation. Laws like Abolition of Untouchability, Child Marriage Prohibition Act, Anti Dowry Laws, Prevention of Sexual Harassment Act, the new laws relating to corporate governance and as recent as artificial intelligence have changed the society for better. The dynamic nature of law has contributed to the constant evolution of mankind. We at Alliance University, School of Law, have always strived to achieve excellence in legal research and are hence organising the National Conference on Law and Social Transformation [NCLS-2021] on March 6, 2021 and this would be annual endeavour in the years to come. We invite people from all the spheres of life ranging from judges, academicians, advocates, NGO representatives, corporate in-house lawyers, research scholars and students for this multi-disciplinary National Conference. The objective of the conference is to bring people from diverse backgrounds to one platform to discuss the lacunae in the legal system and to recommend changes such that it leads to holistic social transformation.

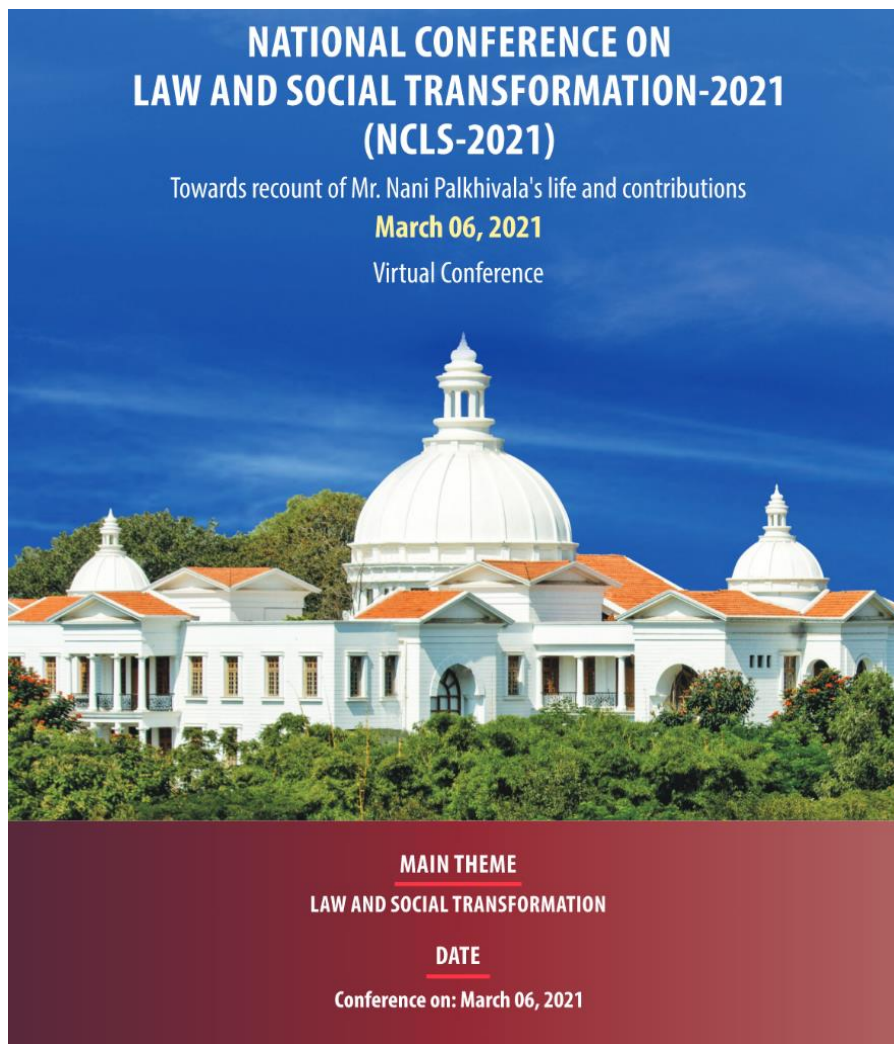

**NATIONAL CONFERENCE ON
LAW AND SOCIAL TRANSFORMATION-2021
(NCLS-2021)**

Towards recount of Mr. Nani Palkhivala's life and contributions

March 06, 2021

Virtual Conference

MAIN THEME
LAW AND SOCIAL TRANSFORMATION

DATE
Conference on: March 06, 2021

Alliance Student Conference (ASCON) 2021

Virtual Conference on June 10th & 11th 2021

Theme: "Global Crises: Business Disruptions and Responses"

Overview:

Crises, such as COVID-19, often disrupt, and most creatively so, the business paradigm and finally lead to a dynamic macro transformation. Such crises may be financial in magnitude, socio-political in ramifications, or even environmental in nature. Such crises result in complex transitions that force businesses to ensure a sustainable position and adapt to the changes. From the perspectives of research, such crises and their impact on business, organization, and market are crucial sites for examination.

The United Nations has currently listed 22 major global issues and 17 SDGs (Sustainable Development Goals) as a 2030 agenda for member countries to usher into a world of peace and prosperity. Such Global issues are the ones for which businesses, organizations, and markets must brace and accordingly prepare.

ASCON 2021 intends to probe how the business/markets/organizations responds to such crises.

ASCON 2021 is a unique student-driven platform designed by Alliance University, Bangalore, India, for students and research scholars from across the globe to showcase their research skills and get trained through workshops by internationally acclaimed experts. The conference pledges to inspire the harbingers of a better world by honing their research potentials.



The image is a promotional card for the Alliance Student Conference (ASCON.b) 2021. At the top left is the Alliance University logo, featuring a circular emblem with a book and a lamp, next to the text 'ALLIANCE UNIVERSITY' and 'Alliance School of Business'. Below this, the conference title 'ALLIANCE STUDENT CONFERENCE (ASCON.b) 2021' and theme 'GLOBAL CRISES: BUSINESS DISRUPTIONS AND RESPONSES' are displayed in white text on a dark red background. A central blue banner reads 'SPEAKERS'. Four speaker portraits are arranged in a 2x2 grid. Each portrait is accompanied by a nameplate containing the speaker's name, title, and affiliation. At the bottom, a dark red bar contains a calendar icon, the dates 'June 10 & 11, 2021', the website URL 'https://www.alliance.edu.in/ascon-2021/', and a play button icon with the text 'VIRTUAL CONFERENCE'.

ALLIANCE UNIVERSITY
Alliance School of Business

ALLIANCE STUDENT CONFERENCE (ASCON.b) 2021
GLOBAL CRISES: BUSINESS DISRUPTIONS AND RESPONSES

SPEAKERS

DR. JUNE COTTE
Scott and Melissa Beattie Professor of Marketing
Ivey Business School
Western University, Ontario, Canada
Continental India

DR. DANNIE KJELDGAARD
Professor, Dept of Marketing and Management
University of Southern Denmark, Denmark

DR. OZLEM SANDIKCI TURKDOGAN
Professor in Marketing (Management)
Adam Smith Business School
University of Glasgow, Scotland, UK

DR. SANJIT K. ROY
Associate Professor of Marketing
UWA Business School
University of Western Australia, Perth, Australia

June 10 & 11, 2021 | <https://www.alliance.edu.in/ascon-2021/> | VIRTUAL CONFERENCE

Critical Organization Studies Workshop

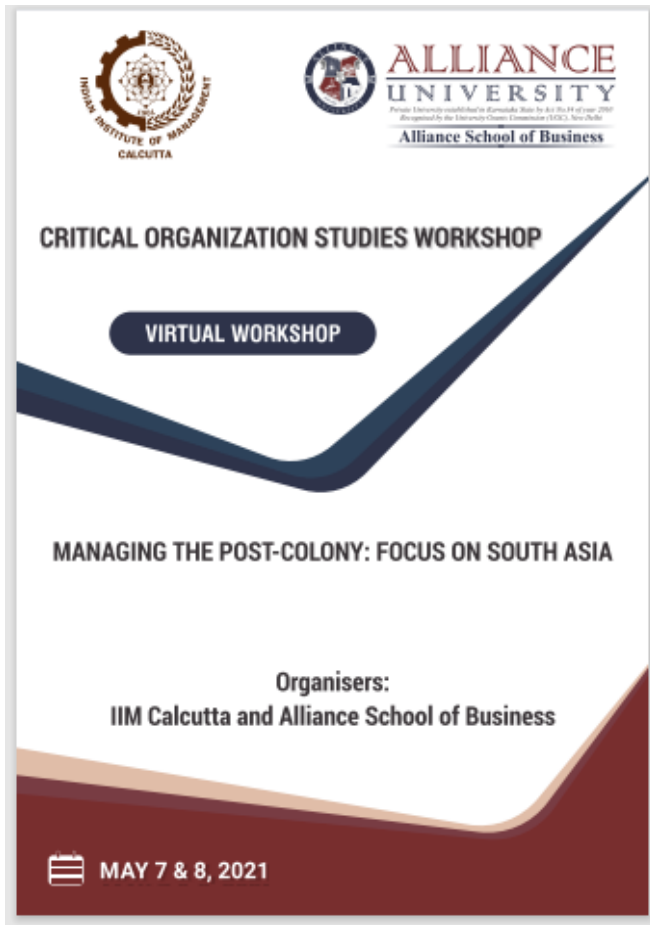

RESOURCE PERSONS



Alex Faria

Associate Professor of Organization Studies and Strategy

Brazilian School of Public & Business Administration at Getulio Vargas Foundation (EBAPE-FGV)



Gavin Jack

Professor of Management

Monash Business School, Department of Management, Australia



Shoab Ul-Haq

Associate Professor

Karachi School of Business and Leadership, Pakistan and Postdoctoral Research Fellow Management School at University of Liege, Belgium

WORKSHOP CO-ORDINATORS



Nimruji Jammulamadaka

Nimruji Jammulamadaka
Professor in the Organization Behaviour Group
IIM Calcutta



Arindam Das

Associate Professor
Alliance Business School
Alliance University, Bangalore

CONFERENCES, SEMINARS & WORKSHOPS

Alliance University and the shift to online learning: Coursera Case Study

As a result of the pandemic and its severity, universities around the world had to quickly transition their learning programs online. Universities that have historically delivered primarily in-classroom instruction had to adapt to virtual learning environments while simultaneously ensuring that their students stay engaged and have access to the right curriculum. Coursera Inc. organized an insightful discussion between Dr. Anubha Singh, Vice Chancellor, Alliance University and Bibin Shivas, Head of Customer Success, APAC, Coursera through a webinar on June 30, 2020. The spotlight was on how Alliance University responded to the pandemic and successfully shifted their learning program online using Coursera for Campus.

Dr. Anubha Singh highlighted key success strategies as well as valuable lessons learned along the way that resulted in Alliance University learners logging over 8700 course completions, 75K hours of learning, and over 1000 learners with 4+ course completions.



Campus spotlight on Alliance University and online learning

Panel Discussion on Redesigning Business Organisation for Resilience:

The Centre for Industry Interaction organized panel discussion, bringing in industry experts from different backgrounds on one platform to discuss and deliberate on a relevant topic.

ALLIANCE UNIVERSITY
Private University established in Karnataka State by Act No. 14 of year 2010
Recognized by the University Grants Commission (UGC), New Delhi
BENGALURU

CELEBRATING 10 YEARS OF ALLIANCE UNIVERSITY

JOIN THE DISCUSSION >

FRIDAY
28 AUGUST, 2020
5:30 PM IST

Ramakrishnan T M
Vice President & Head
JioMart Digital & 4G Devices
Reliance Jio Infocomm

N Rajagopal
Managing Director
Citi, Singapore

Dr. Himanshu Rai
Director
IIM Indore

Vishal Gupta
Global CTO and
Senior Vice President,
Technology, Unisys

Alliance HR Conclave:

Theme: Fostering a Collaborative workforce for the Next Decade

Alliance University hosted virtually the 'Alliance HR Conclave - 2020' themed 'Fostering a Collaborative workforce for the Next Decade' on 25th September 2020 by the Office of Career Advancement & Networking at Alliance University, aims to bring HR leaders across industry verticals to share their views, opinions and ideas on pertinent topics that would focus on creating and nurturing a collaborative workforce.

The sessions would comprise of panel discussions and speaker series where thought leaders and HR practitioners would converge, connect and communicate about strategies and best practices that they have adopted to lead their organizations towards excellence.

The Alliance HR Conclave 2020 will be an exciting amalgamation of best minds in the industry, who would share their stories and enthrall the audience with their rich expertise and add tremendous value to the knowledge community.

Speakers at Alliance HR Conclave 2020



ALLIANCE
UNIVERSITY
*Private University established in Karnataka State by Act No.34 of year 2010
Recognized by the University Grants Commission (UGC), New Delhi*



CELEBRATING
10
YEARS OF
ALLIANCE UNIVERSITY

ALLIANCE HR CONCLAVE 2020

Fostering a Collaborative Workforce for the Next Decade

FRIDAY SEPTEMBER 25, 2020

EMINENT SPEAKERS

 <p>Mr. Ajay Kumar Country Head - HR Continental India</p>	 <p>Mr. Gopi Krishnan TM Business Head (India, Middle East, Asia-Pacific) Vetrotech Saint-Gobain</p>	 <p>Mr. Hasit Trivedi Global Head AI & Automation Service Delivery Infosys</p>	 <p>Lt. Col. Himani Thapliyal Chief Security Officer and Head Plant Admin Vedanta Limited</p>	 <p>Dr. Jayant Kumar Joint President HR Adani Group and SEZ Ltd.</p>
 <p>Mr. Madhu Sundar M S Vice President Dr. Reddy's Laboratories</p>	 <p>Ms. Monika Marwah University Hiring Leader Asia Pacific & Japan NCR Corporation</p>	 <p>Mr. Raj Raghavan Senior Vice President Human Resources Indigo Airlines</p>	 <p>Mr. Rohit Jindal Head - Human Resources Hygienic Research Institute Pvt. Ltd.</p>	 <p>Dr. Sajiv Sankar Team Leader Human Resources Saint-Gobain India Pvt. Ltd.</p>
 <p>Mr. Sandeep Batra Chief Human Resource Officer Landmark Group</p>	 <p>Mr. Santanu Banerjee Chief Human Resources Officer Bajaj Allianz Life Insurance Company</p>	 <p>Mr. Subir Verma Head - Human Resources Tata Power</p>	 <p>Mr. Surya Prakash Mohapatra Global Head Talent Transformation & Global Practice Head Wipro</p>	 <p>Mr. Warner Jude Associate Director Talent Acquisition Cognizant</p>

All India Women Vice-Chancellor 's

The All India Women Vice-Chancellors Round Table was organized at Dr. Babasaheb Ambedkar Open University in Ahmedabad, Gujarat on **March 24, 2021**. Dr. Anubha Singh, Vice-Chancellor, Alliance University was an invited guest at the event and spoke on contribution of women in higher education and also on making education more equitable for all genders.



From Left to Right: Dr. Anubha Singh, Vice-Chancellor, Alliance University; Dr. Pankaj Mittal, Secretary General, AIU; Shri Bhupendrasinh Chudasma, Education Minister, Govt. of Gujarat; and Smt. Vibhavariben Dave, Minister of State for Women & Child Development, Education (Primary & Higher Education) & Pilgrimage



All India Women Vice-Chancellor 's

Association of Indian Universities (AIU) 95th Annual Meet & National Seminar of Vice Chancellors

Alliance University at the Association of Indian Universities (AIU) 95th Annual Meet & National Seminar of Vice Chancellors. The 95th National Seminar of Vice Chancellors was held on **April 14, 2021** on **“Implementing NEP to Transform Higher Education in India”**. The Hon’ble Prime Minister, Shri Narendra Modi highlighted the vision of the National Education Policy which is benchmarked alongside global parameters. The Prime Minister stressed that the NEP should focus on empowering youth through skill-enhancement so that it promotes an Atmanirbhar Bharat. Dr. Anubha Singh, Vice-Chancellor, Alliance University participated in this VC Meet and spoke on governance in implementation of NEP 2020 highlighting how NEP-2020 is a milestone in itself for the education sector and is aligned to the 2030 agenda for sustainable development; built on the foundation pillars of access, equity, quality, affordability and accountability; and that aims to transform India into a vibrant knowledge society and global knowledge superpower.

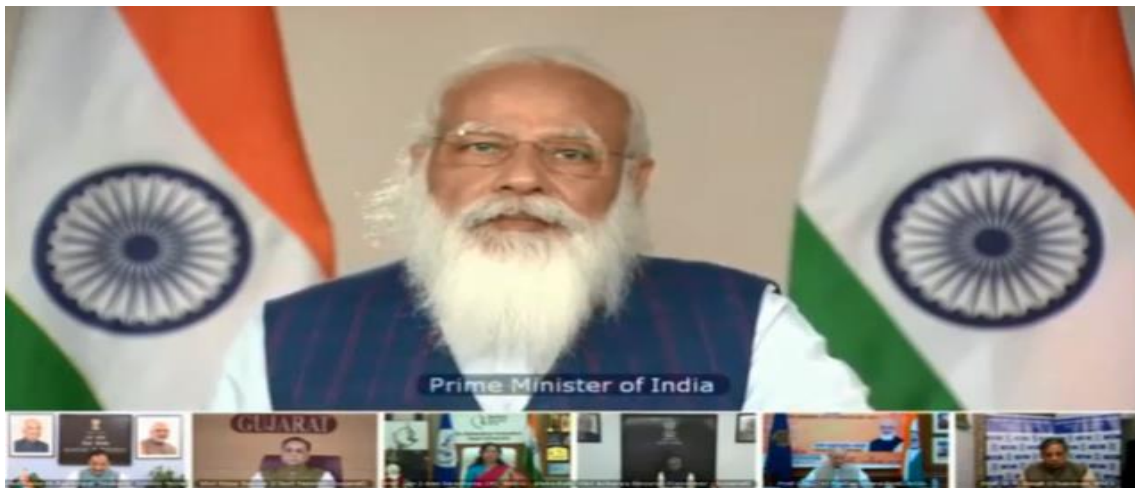

Hon'ble Prime Minister of India, Shri Narendra Modi at the Inaugural Session of the AIU 95th Annual VC Meet



Dr. Anubha Singh, Vice-Chancellor, Alliance University speaking on governance in implementation of NEP 2020 during the AIU Annual VC Meet

HUMAN RESOURCE DEPARTMENT

The Human Resource Department (HRD) at Alliance University is dedicated to managing all people related activities.

The Human Resource Department (HRD) is the framework for helping employees develop their personal and organizational skills, knowledge, and abilities. At Alliance University the focus of all aspects of Human Resource Development is on developing the most superior workforce so that the university and individual employees can accomplish their work goals in service to all our stakeholders.

Report on activities related to HRD

The department is responsible for handling all HR functions across Alliance University and its various academic units:

Recruitment and Selection: Conducts the recruitment of teaching and non-teaching staff following a well-defined process as per the recommendations of statutory bodies to ensure a merit-based selection. The University is an equal opportunity employer. The HRD is responsible for the recruitment at all levels of teaching staff: Assistant Professor, Associate Professor and Professor. HRD is also responsible for staffing non-teaching departments of the University.

Administrative HR: HRD covers staff and faculty leaves and attendance, checking and processing their FDP/MDP applications, issuance of bonafide and No Objection Certificates, travel and related arrangements.

Confirmations and Appraisals: The HRD follows a well-defined process for employee confirmations. The department also facilitates process-driven appraisals of all members of faculty and staff and the documentation of the same. The process is extremely well planned and is kept fair and transparent.

The university provides employees with opportunities to challenge themselves and excel with initiatives like: Job Enrichment, Job Rotation, Faculty Development Programs and encouragement to participate in outreach activities.

Recruitment details

As a dynamic and vibrant academic institute, Alliance University is always in the lookout for a highly qualified and competent talent pool for its teaching and administrative requirements. The onset of the pandemic slowed down the hiring process across industries.

Alliance University on the other hand saw an amazing opportunity in the crisis that the rest of the world was facing. With its academic units in business, engineering and law; Alliance University established new schools and departments in language & literature, media & journalism, sciences, economics, applied mathematics and liberal arts. Launching new schools and departments was the first step and the more crucial step was to build a robust manpower pipeline and to hire talent that would build the founding teams for the new units. This was to be done in addition to the regular hiring for existing schools and programs.

Employee benefits such as medical insurance; on-campus housing:

Medical Insurance

Alliance University has always been aspirational about the welfare of its faculty, staff, and their family members. The University in collaboration with Tata AIG General Insurance Company Ltd. announced a group insurance health policy for Alliance University employees and their family members. The insurance is also structured to cover hospitalization and treatment of “Covid 19”.

On-campus Housing for Faculty & Staff

Alliance University provides best-in-class residential accommodation for its staff and faculty amidst lush greenery; a serene ambience conducive for growth; and inspiring facilities that promote holistic living.

Report on digitisation of activities

The entire recruitment activity was moved to online platforms.



Performance Appraisal: Alliance University, even during the Covid-19 period initiated and executed the annual appraisal for all faculty and staff. The entire exercise was carried out virtually with the use of advanced technology tools. The entire appraisal process right from announcement to data submission to reporting manager review and leadership review was structured on virtual platform.

Recruitment of Faculty & Staff

- 66 new faculty & staff members for the Academic Year 2020-21 were welcomed into the Alliance family.
- The recruitment snapshot is as follows:

Faculty

Department / School	Assistant Professor		Associate Professor		Professor		Grand Total
	Male	Female	Male	Female	Male	Female	
Alliance School of Business	1	1	0	0	0	0	2
Alliance College of Engineering & Design	0	0	1	2	0	0	3
Alliance School of Law	4	4	0	0	2	0	10
Alliance School of Liberal Arts	1	0	0	0	0	0	1
Department of Language & Literature	1	0	0	0	0	0	1
Total	7	5	1	2	2	0	17

Staff

S.No.	Department	Male	Female	Total
1	Office of Admissions	12	20	32
2	Dean's Office - School of Law	1	0	1
3	Finance & Accounts	5	2	7
4	Lab - Aerospace Engineering	1	0	1
5	Office of Branding and Communication	2	0	2
6	Office of Pro Chancellor	1	0	1
7	Office of Chancellor	2	0	2
8	CAN	2	0	2
9	Campus Estate Services	1	0	1
Total		27	22	49

STUDENT ENROLMENT

Enrolment across programs:

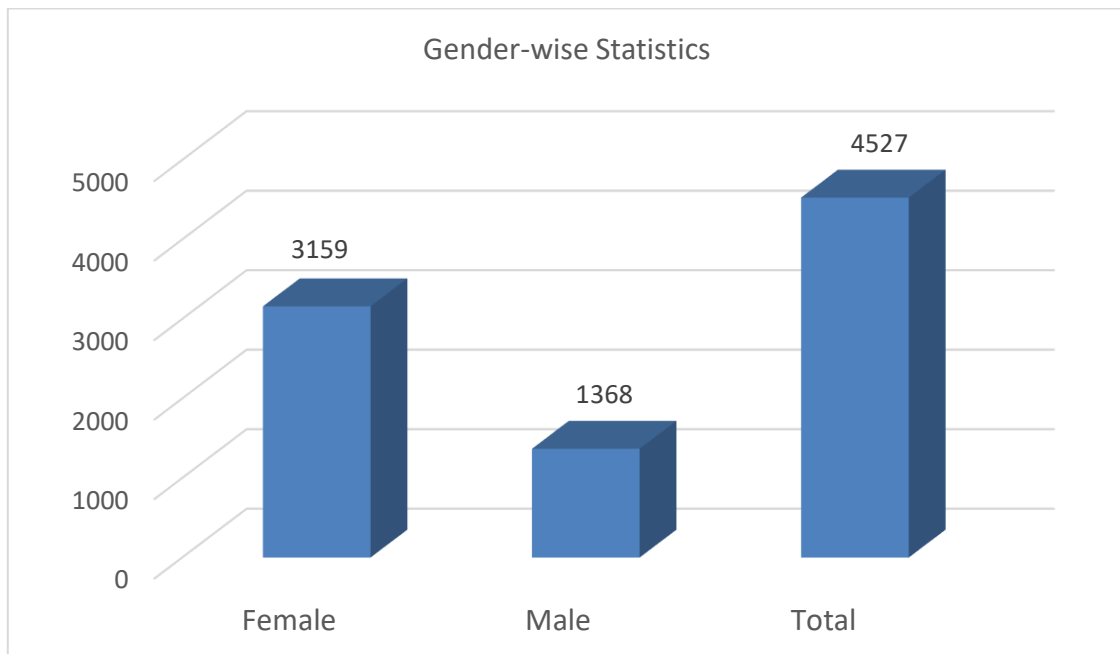
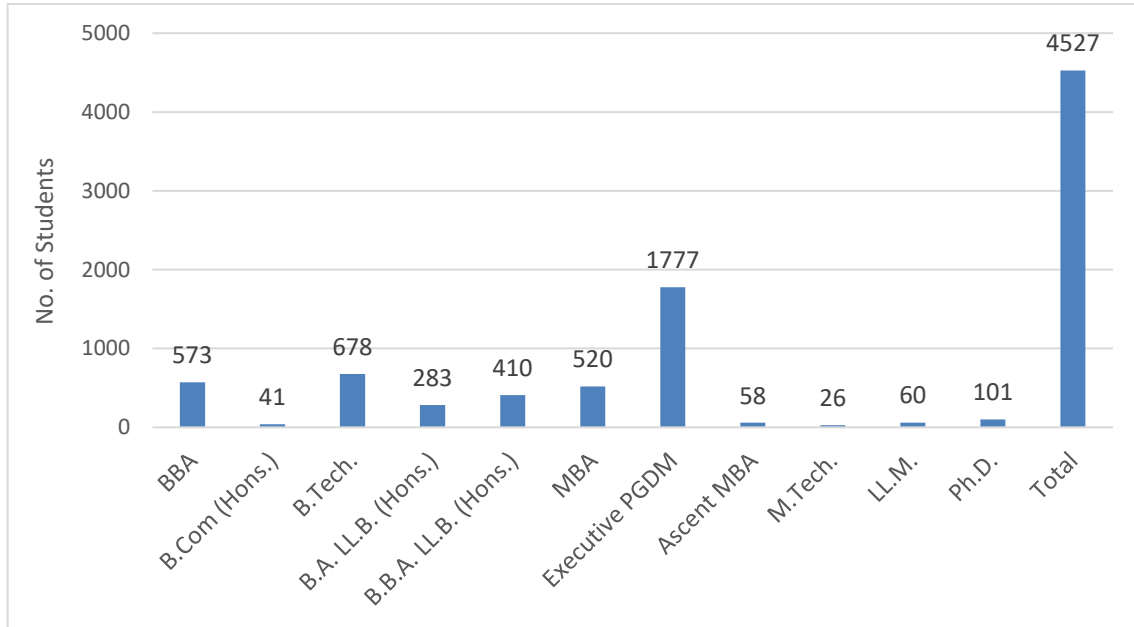

MBA Webinars

Date	Speaker	Topic
12-Nov-20	Dr. Ray Titus	Alliance University Presentation
25-Nov-20	Mr. Pritam Sarkar	Last week before CAT - What to keep in mind
12-Dec-20	Dr. Arindam Das	Stand Out Strategies at Virtual Interviews
19-Dec-20	Dr. R Venkatesh	Creativity Process: Decoded
26-Dec-20	Dr. Kapil Arora	Career in Finance World
28-Dec-21	Dr. Aswathi Nair	How companies should change their HR strategies post Covid
09-Jan-21	Dr. Ajeet Sharma	Pursuing an MBA Degree: What It Takes
16-Jan-21	Mr. Akhil Pruthi & Mr. Sorabh Bajaj	How to build a stellar profile for MBA; GMAT and beyond Alliance University x Coursera
23-Jan-21	Dr. Pratima Verma	Impression Management in Interview
06-Feb-21	Dr. Satyendra Pratap Singh	Investment for Wealth Creation
13-Feb-21	Dr. Aswathi Nair	HR Trends for the Post-Pandemic Workplace
20-Feb-21	Dr. George Easaw	How to bring about innovative/creative thinking in organizations
27-Feb-21	Dr. Sukanya Kundu	Evolution of Digital Business and Information System

Principal Conclave for Undergraduate programs – 2021



ALLIANCE UNIVERSITY
Private University established in Karnataka State by Act No. 14 of year 2008
Recognized by the University Grants Commission (UGC), New Delhi



iEducationalize
Connect to Grow

Counsellors Conference

Reimagining Indian Higher Education: Scope and Opportunities

.....

Speakers:

Dr. Anubha Singh
Vice-Chancellor, Alliance University

Dr. Ray Titus
Dean, Alliance School of Business

Dr. Reeba Korah
Interim Dean, Alliance College of Engineering and Design

Dr. Mukul Saxena
Associate Dean, Centre for Postgraduate Legal Studies

Dr. Dakshayini Khanna
Founding Director - Harvest International School

Mr. A.P Sharma
Principal - Birla Public School, Doha, Qatar

Moderator:
Ms. Shikha Gupta, Director - IEDUCATIONALIZE

Join us
zoom

.....



Dates of the event: 12th December 2020

Topic: Reimagining Indian Higher Education: Scope and Opportunities



ALLIANCE UNIVERSITY
Private University established in Karnataka State by Act No. 14 of year 2008
Recognized by the University Grants Commission (UGC), New Delhi



EDUTV
WORLD EDUCATION BROADCAST

Virtual Principals Conference

The Changing Landscape of Education

Speakers:

Dr. Anubha Singh Vice-Chancellor Alliance University	Dr. Ray Titus Dean Alliance School of Business
Dr. Reeba Korah Interim Dean, Alliance College of Engineering and Design	Dr. Mukul Saxena Associate Dean, Centre for Postgraduate Legal Studies

Time
04:00 pm to 05:30 pm
Date and Day
Friday, Dec 18, 2020

Join us
zoom

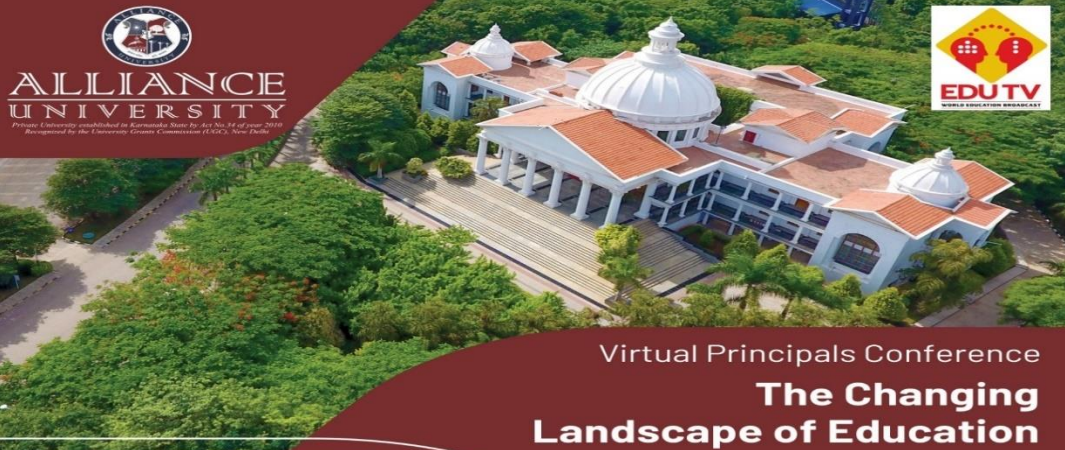

Dates of the event: 18th December 2020

Topic: The Changing Landscape of Education

Counsellors And Teacher's Webinar for Undergraduate programs - 2021

ALLIANCE UNIVERSITY
Private University established in Karnataka State by Act No.34 of year 2010
Recognized by the University Grants Commission (UGC), New Delhi

iEducationalize
Connect to Grow

SPEAKERS

 Dr. Anubha Singh Vice-Chancellor Alliance University	 Dr. Ray Titus Dean Alliance School of Business
 Dr. Reeba Korah Interim Dean Alliance College of Engineering and Design	 Dr. Kiran Gardner Professor & Dean Alliance School of Law
 Mrs. Annu Arora Principal S. L. Suri DAV Public School, Janak Puri, Delhi	 Dr. Rupali Dhamdhare Principal Trinity International School - Pune

MODERATOR

Ms. Shikha Gupta
Director
IEDUCATIONALIZE

Asia's School Leader's, Head and Principal's Webinar

Dates of the event: 10th January 2021

Topic: Transforming Education for the Future

LSAT 2021 Webinar

ALLIANCE UNIVERSITY
Private University established in Karnataka State by Act No.34 of year 2010
Recognized by the University Grants Commission (UGC), New Delhi
Alliance School of Law

LSAC Global

How to Prepare for a Successful Legal Profession

 DR. KIRAN GARDNER Professor & Dean Alliance School of Law, Alliance University	 DR. JASON DICKENSON Director India Testing at the LSAC Global	 MR. ADITHYA PRAVEEN Legal Associate Alumni of Alliance School of Law BA.LLB-2020
---	--	--

 April 19, 2021  5:00 PM to 6:00 PM

LSAT 2021 Webinar 11th May 2021



DECODING LAW COLLEGES IN 2021: LEADERSHIP'S TALK



Mr. Yusuf
Abdul-Kareem
Vice President
Emerging Markets, LSAC



Prof. (Dr.)
Kiran Gardner
Dean
Alliance School of Law



Prof. (Dr.) Alok Misra
Dean
SVKM'S NMIMS Kirit P.
Mehta School of Law



Prof. (Dr.)
Akhilesh Kumar Khan
Director, Admissions
Deputy Director
Lloyd Law College



Prof. (Dr.)
Nuzhat Parveen Khan
Dean
School of Law
Bennett University



Prof. (Dr.)
Tabrez Ahmad
Vice Chancellor and Dean
GD Goenka University

Principal's Get Together on 23rd January 2021



LIBRARY RESOURCES

Introduction:

Central Library plays a vital role in furthering the academic and research mission of Alliance University and facilitates creation and dissemination of knowledge. The Central library has one of the best collections of information sources in management, science and technology and law-related disciplines. The library has a large collection of text, reference books and multimedia, which is continuously updated with the latest editions.

It subscribes to national and international periodicals, databases and online journals. The library maintains a website through which students can access online databases, journals and catalogues anywhere in the world. The library has a digital library providing a full-text collection of documents and faculty publications. It has ample reading room facilities spread over four floors with a seating capacity for over 1,000 students.

Collection building is one of the important functions of the library that supports academic and research work of the students, faculty, staff and other users. Library collection comprising of books, journals, case studies, CD-ROMs, reports, and other reading material in engineering, technology, law, social sciences and management. The New three sections have been established such as Skill Zone, Competitive Exam Corner and Language section (Kannada, Hindi & Sanskrit).

Resources	Total
Books	75957
Periodicals	32
CD/DVD's	2558
Bound Volumes of Journals	2711
Dissertation & Theses	115
Online Resources /Databases	22

About Digital Library

The Digital Library is housed on the first floor of the library and is equipped with computers connected with Internet for users to search and browse information on electronic Databases, e-Journals, e-books as well as Audio books and CD/DVD's. The Digital Library Section resources are available for all the users and also responsible for developing, managing and supporting digital library collection and services.

Central Library has its own Intranet homepage (<http://library>) and provides web-based access to its resources. The library procures journals and databases, supports online submission of faculty publications and has set up an institutional repository of publications brought out by the Alliance community. The library is a part of the institute-wide network and has adequate computing infrastructure to cater to the needs of the users. The WI-FI facility in the reading area continues to attract users to bring in their laptops to have seamless access to print and electronic resources.

OPAC (Online Public Access Catalogue)

The OPAC (<http://library.alliance.edu.in>) is one of the most heavily used databases of the library and is accessible 24x7 via library web page. Besides listing all the documents available in the library, it allows on-line renewal and reservation, circulation, fine collection, and indicates status of a particular book. OPAC is searchable by author, title, accession number, subject and several other fields.

Library Features:

- Independent Building with four floors - Total area 55,000 Sq. ft.
- Wi-Fi Connectivity
- Fully Automated with Bar-Code Technology
- Library Catalogue is hosted in Cloud and accessible Worldwide
- Digital Library with multimedia facility
- Library portal (Website)
- Disabled friendly building with Lift facility for all the floors

Library Events & Activities

The Central Library has organized following events and activities during the year 2020-21.

International Day of Yoga:

The Central Library and NDLI club organized an online quiz to create awareness on Yoga on 26th June 2021.

World Book and Copyright Day & World Intellectual Property Day:

Online Quiz Competition organized for all the users on 26th April 2021

Open Educational Week:

Central Library observed Open Educational Week from 1st March to 5th March 2021 to promote the open educational resources.

International Mother Language Day (Matribhasha Diwas):

The Central Library in association with Kannada Bhasha Kendra and NDLI Club organized online Quiz competition and Book Display on languages on 20th February 2021

National Youth Day:

Central Library and NDLI Club organized an Online Quiz and Book Display on the occasion of Swami Vivekananda's 158th birth anniversary on January 12, 2021

National Library Week:

14th to 20th November is being celebrated as the National Library Week all over India and various programs are held to enhance user awareness about library resources and services. Keeping in tune with this tradition, The Central Library celebrated the National Library Week as mentioned below:

- Nov 17, 2020 Online Quiz on "Educational Resources and Services"
- Nov 18, 2020 Essay Writing Competition on "Importance of Digital Library During COVID-19 Scenario"
- Nov 19, 2020 Alliance University, Central Library in Association with Karnataka State Library Association (KALA) organized Webinar on "Redesigning of Library Services in the COVID-19 Scenario & Beyond" for Library Professionals.
- Nov 20, 2020 Alliance University NDLI Club in Association with National Digital Library of India, Under Ministry of Human Resources Development, Govt. of India and Indian Institute of Technology (IIT), Kharagpur organized User Awareness Program on "National Digital Library of India" for all the faculty members, Staff and Students.
- Students from across disciplines participated with zeal and enthusiasm. The program ended with a grand finale. The Registrar graced the valedictory function. Prizes were given a way to the toppers of the events.



National Library Week Lighting the Lamp



National Library Week Celebrations– 17-20, November 2020

Saraswathi Pooja at Central Library:

On the auspicious occasion of Dasara, the sacred Saraswathi Pooja was celebrated with much reverence in the Alliance University Central Library on 21st October 2020 to pray to the Goddess of Knowledge. Vice Chancellor, Registrar, Dy. Registrar, Deans, Hod's, Teaching and Non-Teaching Staff members joined the auspicious pooja and received the blessing of Lord Ganesha and Saraswathi. Prasadam was distributed to all after Mahamangalarathi.



Saraswathi pooja celebrations at Central Library- 21st October 2020

Training Programs:

User awareness is an important regular activity of the library to inform, alert, educate and train users about various resources and services of the library. In addition to orientation programs for new batch of students, library conducted training programs on How to Use e-resources for faculty members, Research Scholars, and students so that they can use these resources more effectively.

- May 29, 2021: Central Library organized Know Your Library Session on Library Resources and Services for Law Students
- May 22, 2021: Central Library organized Know Your Library Session on Library Resources and Services for all the Research Scholars.
- May 19, 2021: User Awareness program and Training Session on J-Gate database for all the faculty members, Research Scholars, and students
- April 8, 2021: Training Session on LexisNexis Legal database for all the Law faculty members and students.

- February 22, 2021: Online Training Session organized on SCC and MyLOFT Remote Access service to all the Law faculty members and students.
- December 24, 2020: Central Library has taken Institutional Membership with DELNET to access the wide range of Books, Journals, and other materials. In this regard, library organized a training session on How to access Delnet Discovery portal and its resources through online mode.
- November 19, 2020: Training program on “URKUND: Plagiarism Detection Software” all the faculty members.

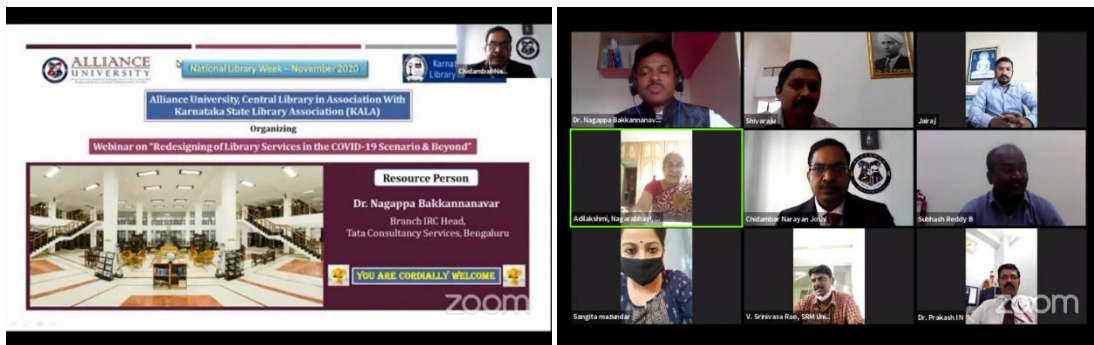

Webinar on “Redesigning of Library Services in the COVID-19 Scenario & Beyond” organized in Association with Karnataka State Library Association (KALA) – 19th November 2020

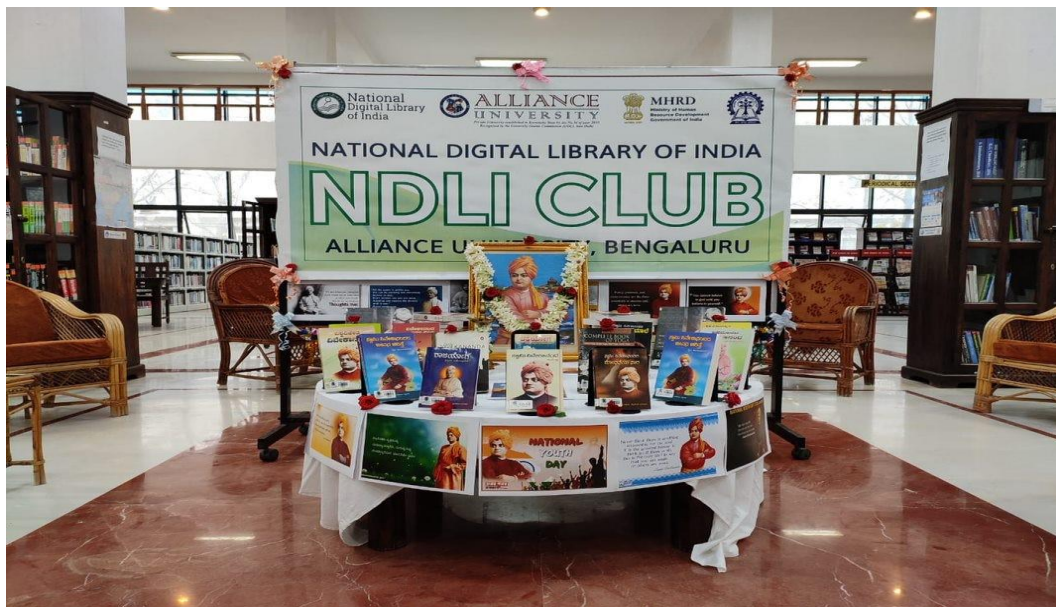

Book Display on the occasion of Swami Vivekananda’s 158th birth anniversary – 12th January 2021

OFFICE OF INTERNATIONAL AFFAIRS

Alliance University has several articulation agreements with many accredited universities across the world. Through the collaborative arrangements with international universities, Alliance University develops study-abroad programs and facilitates educational experiences in several countries such as Belgium, Canada, China, France, Germany, Italy, Netherlands, Russia, Sweden, Switzerland, Taiwan, UK and USA. Apart from providing an opportunity to understand different cultures in a globalized economy, these programs provide students with the opportunity to gain first-hand international experience and to develop as global citizens.

In order to augment students' intellectual, professional, and personal development there are several international educational opportunities for the students. To meet the diverse needs of the student population, the Office of International Affairs offers a variety of options such as the semester exchange program, dual-degree program, credit transfer program and the summer program. Aspiring students are encouraged to consider international programs to advance their academic goals.

International Partners:

New International Collaborations 2020-21:

Partner University Name	MOU / Articulation Type	New / Renewal	AU Schools	Programs
Birmingham City University, UK	General Agreement	New	ASOB, ASOL & ACED	ALL
Western Sydney University, Australia	General Agreement	New	ASOB & ACED	ALL
San Jose State University, USA	Student Exchange Agreement	Renewal	ASOB	MBA
University of Strathclyde, UK	Credit Transfer Articulation Agreement	New	ACED	B. Tech.

International Faculty at Alliance University 2020-21:

Name	University / Institution
Dr. Bhumika Gupta	IMT-BS, France
Mr. Haydn Powell	Caterpillar Inc. USA

Outgoing students on international programs:

CREDIT TRANSFER PROGRAM (BBA) - Fall 2020	
Student Name	International Partner Name
Mr. Sri Rishi Yendluri	IPAC School of Management, France

CREDIT TRANSFER PROGRAM (B. TECH. Aerospace Engineering) – Fall 2021	
Student Name	International Partner Name
Mr. Rushil Midha	University of Strathclyde, UK

SEMESTER EXCHANGE PROGRAM (BBA) – Fall 2021	
Student Name	International Partner Name
Ms. Prerana Vijay Ravatale	Institut Mines Telecom – Business School, France

SEMESTER EXCHANGE PROGRAM (MBA) – Fall 2021	
Student Name	International Partner Name
Ms. Kanishka Arya	San Jose State University, USA
Mr. Chiru Naga Satish Kunapareddy	San Jose State University, USA
Mr. Yedukondalu Katari	San Jose State University, USA
Mr. Mohammed Asif	San Jose State University, USA

Alliance University Students on International Programs

AU MBA Students on Fall 2021 Semester Exchange Program at **San Jose State University, USA**





AU B. Tech. Student on Credit Transfer Program at University of Strathclyde, Glasgow, UK

Webinars:

University Name	Speakers	Date	Topic
UK-India Education & Research Initiative - UK	V. Ram Gopal Rao, Director, IIT Delhi. Professor Neil Robertson, Chair of Molecular Materials, University of Edinburgh. Professor Samit Kumar Ray, Director, SN Bose National Centre for Basic Sciences, Kolkata. Professor Ratnamala Chatterjee, Head of Department-Physics, Indian Institute of Technology Delhi (SPARC grantee). Professor Charl FJ FAUL, Professor of Materials Chemistry Head, University of Bristol (SPARC grantee)	1-Jul-20	International Webinar for BTECH Students Webinar Topic: 2D & Nanostructured Phenomenon, Materials & Devices
UK-India Education & Research Initiative - UK	Dr Radhika Govinda, Senior Lecturer in Sociology, University of Edinburgh. Professor Purnima Singh, Head of Department- Humanities and Social Sciences, Indian Institute of Technology Delhi. Professor Ann Stewart, Professor, School of Law, University of Warwick. Dr Emily Henderson, Associate Professor, Centre for Education Studies, University of Warwick. Professor Nidhi. S Sabharwal Associate Professor, Centre for Policy Research in Higher Education, NIEPA	6-Jul-20	International Webinar for BTECH Students Webinar Topic: Sociology, Psychology & Gender Studies
The French Embassy in India & Campus France	French Institutions Panelists: Dr Pierre François, Science Po; Dr Marion Fortin, Toulouse School of Management; Dr Sebastian Bervoets, Université d'Aix Marseille	21-Sep-20	PhD Tour Webinars Topic: Economics and Social sciences

University Name	Speakers	Date	Topic
The French Embassy in India & Campus France	French Institutions Panelists: Dr Marion Fortin & Dr Sandra Laporte, Toulouse School of Management; Dr Olivier Bruno & Dr Cécile Ayerbe, Université Côte d'Azur; Ms Britta Delhay, HEC.	21-Sep-20	PhD Tour Webinars Topic: Management
The French Embassy in India & Campus France	French Institutions Panelists: Dr. Edmond Rock, Institut National de la Recherche Agronomique (INRAE); Dr Magali Dufour, Centre de coopération internationale en recherche agronomique pour le développement (CIRAD); Prof Véronique Gayraud, Université de Toulouse	22-Sep-20	PhD Tour Webinars Topic: Ecology, Biodiversity, Agronomy
The French Embassy in India & Campus France	French Institutions Panelists: Dr Catherine Schuster, Université de Strasbourg; Dr Jonathan Ewbank, Université d'Aix Marseille; Prof Sandrine Onger, Université Paris Saclay; Dr Andreas Niebel, Laboratoire des Interactions Plantes Micro-organismes (LPIM)	22-Sep-20	PhD Tour Webinars Topic: Health Sciences
The French Embassy in India & Campus France	French Institutions Panelists: Prof Andreas Hartmann, Université de Bordeaux; Prof Stéphane Nonnenacher, Université Paris Saclay; Ms Mylaine Clément, Université de Montpellier; Prof Jean-François Naviner, Telecom Paris, Institut Polytechnique de Paris	23-Sep-20	PhD Tour Webinars Topic: Mathematics

University Name	Speakers	Date	Topic
The French Embassy in India & Campus France	French Institutions Panelists: Prof Yannick Hoarau, Université de Strasbourg; Prof Aurélien Debelle, Université Paris Saclay; Prof Hanène Souli, ENISE	23-Sep-20	PhD Tour Webinars Topic: Physics / Chemistry / Materials
The French Embassy in India & Campus France	French Institutions Panelists: Prof Alain Sibille, Telecom Paris, Institut Polytechnique de Paris; Prof Yann Busnel, IMT Atlantique; Prof Andreas Hartmann, Université de Bordeaux	24-Sep-20	PhD Tour Webinars Topic: Information Technology & Artificial Intelligence
The French Embassy in India & Campus France	French Institutions Panelists: Prof Sylvain Franger, Université Paris Saclay; Prof Christine Gérardin, Ecole Doctorale SIMPPÉ, Université de Lorraine; Prof Jean-Marc Laheurte, Université Gustave Eiffel	24-Sep-20	PhD Tour Webinars Topic: Engineering Science and Sustainable Development
The French Embassy in India & Campus France	French Institutions Panelists: Mr Alexandre Stegner, Ecole Polytechnique, Institut Polytechnique de Paris; Prof Marie-Odile Simonnot, Université de Lorraine; Prof Catherine Pantel, Toulouse INP	25-Sep-20	PhD Tour Webinars Topic: Energy and Process
The French Embassy in India & Campus France	French Institutions Panelists: Prof Franck Plunian, Université de Grenoble Alpes; Prof Laurence Vidal, Université d'Aix Marseille; Dr Jérôme Van der Woerd, Université de Strasbourg	25-Sep-20	PhD Tour Webinars Topic: Earth & Space Sciences

University Name	Speakers	Date	Topic
University of Sheffield, UK	Speaker: Professor Jon Barker, Department of Computer Science, The University of Sheffield, UK	10-Mar-21	British Council Masterclass Lecture Topic: Artificial Intelligence and the Deep Learning Revolution
University of Strathclyde, UK	Speaker: Dr. Athanasios Toupis, Department of Mechanical and Aerospace Engineering, University of Strathclyde, Glasgow, UK	8-Apr-21	International Faculty Lecture Session Lecture Topic: Engineering Materials Selection
University of Strathclyde, UK	Speaker: Dr Martin Given, Department of Electronic and Electrical Engineering, University of Strathclyde, Glasgow, UK	9-Apr-21	International Faculty Lecture Session Lecture Topic: Transmission Lines and Time Domain Reflectometry

Hackathon:

University Name	Attendees	Date	Topic
University of Queensland, Australia	ACED Team: Aerospace Engineering Team Participant 1: Hrithik Thukral; Participant 2: Khatri Arjun Rajendran; Participant 3: Joisar Priyesh Jitendra; Academic Mentor: Prof. Hariprasad Timmegowda	2 Weeks - 8-21 October 2020	Engineering Design Hackathon

Guest Lecture:

University Name	Speaker	Date	Topic
Bond University - Queensland - AUSTRALIA	Dr. Jeffrey Brand	30-Oct-20	International Webinar for BTECH Students Webinar Topic: Living & Working in the Post-Pandemic Digital Media World
Bond University - Queensland - AUSTRALIA	Dr. Steven Stern	25-Nov-20	International Webinar for BTECH Students Webinar Topic: Big Data - The Power and Perils of Modern Data Analytics
Bond University - Queensland - AUSTRALIA	Prof. Chris Knapp	26-Nov-20	International Webinar for BTECH Students Webinar Topic: Current Issues facing Architectural Practice Locally, Naturally and Internationally
Bond University - Queensland - AUSTRALIA	Prof. Bruce Vanstone	27-Nov-20	International Webinar for BTECH Students Webinar Topic: Introduction to Machine Learning - Gradient Descent
Livingstone College, USA	Dr. Colin Pillay	24 May 2021	International Guest Faculty Lecture

Joint Research Project:

University Name	Attendees	Date	Topic
Ulster University – UK	Participants: Dr. Hue Wang - University of Ulster, UK; Dr. David Glass - University of Ulster, UK; Dr. Selvarani - Alliance University	2 Months September - October 2020	UK-India Innovation Challenge Fund 2020

OFFICE OF CAREER ADVANCEMENT AND NETWORKING

The Career Advancement and Networking (CAN) office at Alliance University is an interface between industry practitioners and the student-body of Alliance University, facilitating both entities to make strategic hiring and career decisions.

Recruiter Details for 2020-21 Placement Cycle (Sector Wise)

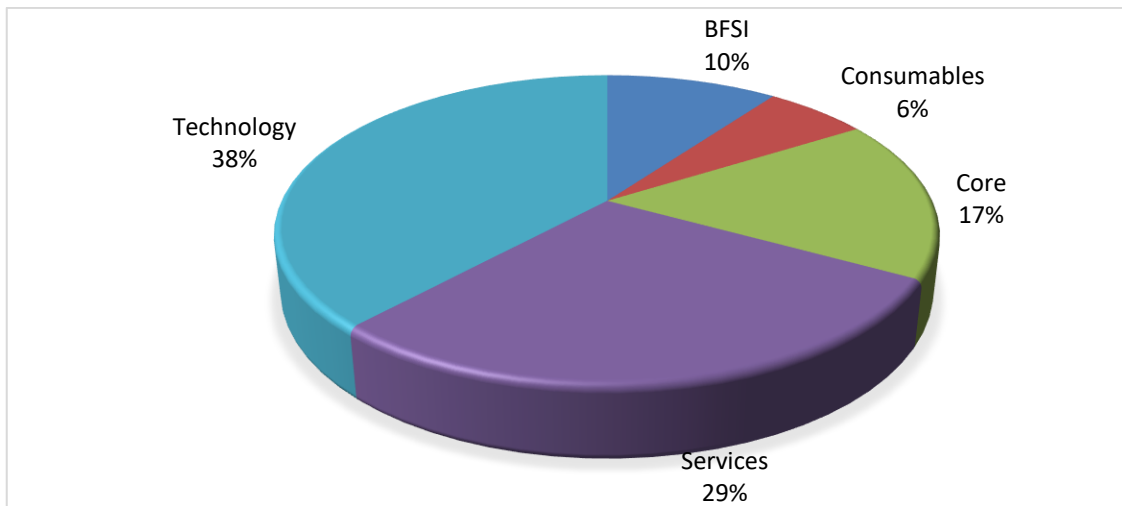

Campus Recruitment Overview

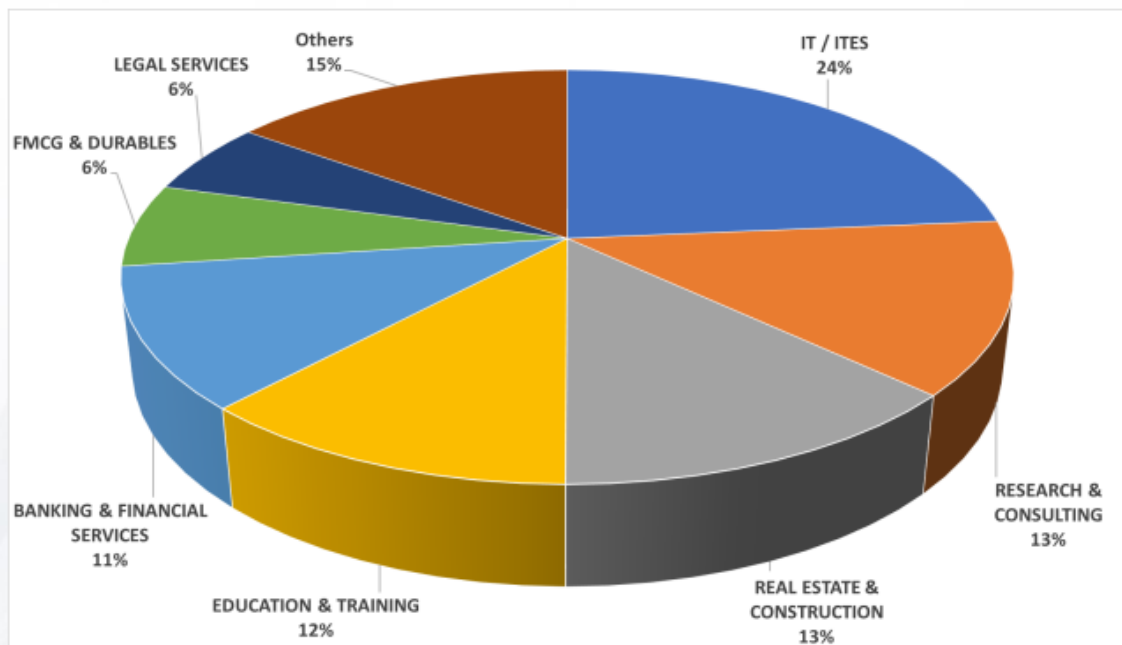

Renowned companies participated in the placement cycle of 2020-21 recruiting talented students from different programs of Alliance University.

Center for Industry Interaction

Centre for Industry Interaction (CII) provides an interface between the academic and the corporate world through interactive sessions organized at the Alliance University. Leading practitioners from diverse industry backgrounds share their insights and experiences through interactive sessions with students.

As a facilitator between academics and the corporate, the Centre for Industry Interaction creates distinct spill-over benefits for the University in areas such as, curriculum review, alignment with 'recruiter expectations,' and as reinforcement for wider internship and campus placements opportunities for students.

Last year the Centre invited many experts from diverse industry sectors. Due to the onset of the pandemic, the Centre arranged for expert talks online and was able to source in leaders from across the globe for talks and sessions.

CII Events:

Industry Exposure Visits:

The Centre arranges for students to visit different companies as part of experiential learning. As part of visits to different companies, students get to understand aspects such as supply chain, production, logistics, cost management, vendor management, imports and exports.

With a view to enable the students to understand and relate the practices followed by the corporates Vis-a-vis the management lessons / theories' taught in the classroom, the Centre for Industry Interaction has arranged for the following Industry Exposure Visits during the year. These visits include a campus tour to the facility within the permissible area followed by an interaction furnishing certain management insights by one of the Senior Officials of the Industry to understand overall functioning of the organization.

Some of the companies that students visited for industry exposure:

- Toyota
- Tata Solar



Industry Visit to Toyota



Industry Visit to Tata Solar

Expert Talk Series:

The Centre also arranged for senior industry to address the students on a variety of topics. Industry experts managing business, operations, legal functions, sales, etc. shared their views with students on different aspects.

Date	Speaker	Designation	Organization
August 6, 2020	Thaj Mathew	General Counsel	Honeywell Technologies
August 7, 2020	Binoy K	Manager Talent Acquisition	Wipro Technologies
August 8, 2020	Mohan Kumar	Practice Head	Wipro Limited
August 12, 2020	RamKumar Warriar	Senior Vice President	Aptech Ltd
August 13, 2020	Parveen Mahtani	Chief Legal officer	Mahindra Lifespaces
August 14, 2020	Dennis Groenveld	Director - Consulting Services, Digital	Wipro Limited
August 17, 2020	Shailesh Vilankar	Senior Vice President	Schindler
August 19, 2020	Jonas Prasanna	International HR Business Partner	Boeing
August 20, 2020	Aravind Ajad	Fellow, Distinguished Member of technical Staff, Connected Enterprise Platform	Wipro Limited
August 20, 2020	Anil P M	EVP -Legal & Chief Compliance Officer	Bajaj Allianz Life Insurance Company Limited
August 21, 2020	Ashok Bhat	Chief Delivery Officer – Global Delivery Head	Acronotics
August 25, 2020	Manoj Tiwari	Lead Architect, Cloud Technologies	Wipro Limited
August 26, 2020	Srinidhi Sharma Rao	Senior Partner	TheMathCompany
August 27, 2020	Sai Krishnan P M	Vice President	Legal & Company Secretarial

Date	Speaker	Designation	Organization
August 27, 2020	Venkatramani Prakash	Vice President & Head Business Retail	Ebixcash
August 28, 2020	Ramakrishnan T M	Vice President and Head	Reliance Jio telecom
August 28, 2020	N Rajagopal	Managing Director	Citi, Singapore
August 28, 2020	Himanshu Rai	Director	IIM Indore
August 28, 2020	Vishal Gupta	Global CTO and Vice President-Technology	Unisys
August 29, 2020	Mathangi	Vice President	Gojek
September 3, 2020	Nilanjan Banerjee	Head - Risk & Legal	eClerx
September 11, 2020	Rashmi Deshpande	Partner	Khaitan & Co.
September 17, 2020	Prashanth Sabeshan	Partners	AZB & Partners
September 17, 2020	Ashish Chandra	CEO & Managing Director	Airtel, Srilanka
October 16, 2020	Sundara Sukavanam	President & Chief Digital Office	Firstsource Solutions, USA
November 3, 2020	Bahram Vakil	Co-Founder	AZB & Partners
December 1, 2020	Amith Prakash	Diversity & Inclusion, Employee Engagement & Experience Centre of Excellence	HCL Technologies Ltd
December 21, 2020	Vishawanadh Raju	Global Head –Talent Acquisition	Axiscades
December 22, 2020	Srijith V	Delivery Manager & Agile Coach	Tata Consultancy Services
January 28, 2021	Padmanabhan	Head, Delivery Excellence Group	Mindtree

Date	Speaker	Designation	Organization
March 20, 2021	Vishwanath Raju	Head-India Talent Acquisition	Dun & Bradstreet
March 20, 2021	Ashish Thakur	Director-Projects	Cognizant
March 20, 2021	Rishi K	Associate Director	Cushman & Wakefield
March 20, 2021	Shankar Shivakumar	Associate Director	Moody's Analytics
March 20, 2021	Tanvi Thacker	Head-Employee Benefits	Infosys
March 25, 2021	Rashmi Deshpande	Partner	Khaitan & Co.
March 25, 2021	Adv. Rashmi Deshpande	Partner	Khaitan & Co
April 3, 2021	Deepto Roy	Partner	Shardul Amarchand Mangaldas, Mumbai
April 9, 2021	Prakash V	Director-Payments India	Flywire
April 10, 2021	Adv. Biswajit Sarkar	Founder	Biswajit Sarkar, Advocates & IP Lawyers
April 16, 2021	Raghavendra A	Sr. Vice President & Zonal Head	RBL Bank
April 24, 2021	Sai Krishnan PM	Head of Client Documentation Group Legal & Company Secretarial	HSBC EDP, Bangalore
April 30, 2021	Ravi Rajiv Upadhyay	Head of legal & compliance operations	Ameriprise Financials
May 7, 2021	Kishore Shetty	General Counsel (India Zone)	Schneider Electric
May 14, 2021	Sammanika Rawat	Legal Career Coach	Former Head of placements LawSikho

Date	Speaker	Designation	Organization
May 21, 2021	Harsha R.	Mechanical Design Engineer	Boeing
May 21, 2021	Karthik B. Murthy	Legal Retainer	Titan Company Ltd.
May 26, 2021	Dhurai Ganesan	Vice President	NASSCOM
May 28, 2021	Adv. Devesh Saxena	-	Allahabad High Court
May 28, 2021	Adv. Surangama Sharma	-	Allahabad High Court
May 28, 2021	Adv. Kanisth Ganeriwal	-	Punjab & Haryana High Court
June 4, 2021	Aravind Ajad	Chief Architect & Wipro Fellow	Wipro Digital
June 5, 2021	Col. Vinod Kumar Karicheri	Global Project & Governance, Lead Data Privacy	HCL Technologies
June 12, 2021	C.B.S. Mani	Director-HR	CGI
June 18, 2021	Ritwik Batabyal	Legal Retainer	Global Delivery Head
June 19, 2021	Siddharth Somani	Global Webinar Execution Specilaist	NetApp
June 25, 2021	Al Rafeeq Moideen	General Manager - Legal	Mangalore Refinery & Petrochemicals Limited
June 26, 2021	Rajesh Pawar	Senior Vice President	Cigniti

Industry Collaborations:

The partnership with ICT Academy plays an instrumental role in creating the next generation talent pool by providing state-of-the-art, industry-relevant curriculum and international certifications. The trainings and certifications are provided through ICT Academy are by leading companies. Details of some of the trainings and certifications are captured below:

VM Ware

- VCA certification
- Free software products for Training and Development
- VMware authorized courses for students and faculty

Salesforce

- Salesforce certification courses
- Supported through trainers and resource persons
- Faculty development programs

Oracle

- Courses on Oracle 11g, Java etc.
- Free Software access and online learning for teachers
- Free access to Oracle Academy service

Dell EMC

- Courses and training programs on niche IT Technologies including Cloud Computing, Big Data Analytics, Storage and Security
- Free online resources

AutoDesk

- Courses and content resources on Digital Prototyping and Building Information Modelling courses
- Free Autodesk software
- Trainers and resource persons

Amazon Web Services

- Access to AWS academy and AWS educate program
- Resources and industry guidance

List of Recruiting Partners for 2019-20 Placement Cycle

99acres.Com	Apnetime Technologies Pvt. Ltd.	Bhilai Steel Plant (SAIL)
Aagnaa Software Labs Pvt. Ltd.	Apollo Hospital	Biocon
ABM Project	Apollo Tyres Ltd.	Bihar Human Rights Commission
Abyeti Technologies Pvt. Ltd.	Applied Materials India	Bihar State Legal Service Authority
ACC Ltd.	Aptean India Pvt. Ltd.	Bilaspur Mining Industries Pvt. Ltd.
Accolite Software India Pvt. Ltd.	Aquagenics R&D India Ltd.	Bill Forge Pvt. Ltd.
Accenture Technologies.	Arcesium	Birla Shakti Cement Division of Kesoram Industries Ltd.
Acer India Pvt. Ltd.	Armstrong World Industries (India) Pvt. Ltd.	Bisleri International Pvt. Ltd.
Acumen Capital Ltd.	Arvind Fashions Ltd	Biztime IT Solutions Pvt. Ltd.
Axiom Consulting Pvt. Ltd.	Artech Infosystems Pvt. Ltd.	Blacks and Whites Law Consultants LLP
Adda	Arubani Odin Media Pvt Ltd (AOM Studios)	Blowhorn
Address Home Retail Pvt. Ltd.	Ashi Legal	Blue Ocean Ventures
Adecco	Ashok Leyland Pvt. Ltd.	Blue Yonder
Aditya Birla Fashion & Retail	Aspersion Tech	BMC Software India Pvt Ltd
Adlink Media Pvt. Ltd.	Aspire Systems	BMW Pvt. Ltd
Adobe Systems India Pvt. Ltd.	Asteria Aerospace Private Limited	BNY Mellon
Advocates Pedia	Atos	Board Infinity
Aeronautical Development Establishment	Atos Syntel	Bodycraft
Again Drinks (Bachfun Pvt. Ltd.)	Atos Global IT Solutions and Services Private Limited	Bolloré Logistics
Agrya Consultating Pvt.Ltd.	AU Small Finance Bank	Bosch India
Ahastiya Legal	Auriga International Management Consultancy	Botbakery
Air India Limited	Avtec Pvt. Ltd.	Britannia Industries Limited
Aircare System & Solution India Pvt. Ltd.	Axio Bio Solutions	Brite Camp
Airtel	Axis Bank	BSNL
Akrity Computing	Azure Skynet Solutions Pvt Ltd	Buddha Toyota Motors Pvt. Ltd.
Algotherm	B&B Associates LLP	Business Setup Worldwide
Alpha Partners	Bachfun Pvt. Ltd. (Again Drinks)	Buzibrains
Altair Engineering India	Bail Aircraft Industries Pvt. Ltd.	Byju'S
Amazon India	Bajaj Allianz General Insurance Co.	CK Juris
Ambit Power Solutions Pvt Ltd.	Balaji & Associates	CDAC
American Express Banking Corporation	BananalP	Cafe Coffee Day
Ameriprise Financial	Bangalore Aircraft Industries Pvt. Ltd.	Camp Arbitration & Mediation Practice Pvt. Ltd.
Amsburg Industries Pvt. Ltd.	Bangalore International Airport Ltd.	Can Fin Homes Ltd.
Analytical Investments	Bangalore Mediation Centre	Canvasjs
Anand Rathi	Basket Option Insurance Brokers Pvt. Ltd.	Capgemini
Anar	Bayer Crop Sciences India Ltd.	CapitalVia Global Research Ltd.
Anarock Property Consultants Pvt. Ltd.	Begorra Infrastructures and Developers Pvt. Ltd.	Capillary Technologies
Anu Products Ltd.	Belong.Co	Capricorn Logistics
Anup S Shah Law Firm	BEML Ltd.	Care International
Anuswaryaa Enterprises Private Ltd.	Bennett Coleman & Co. Ltd.	Cargo Assistance Release Express LLC
ANZ	Berger Paints India Limited	Catchpoint
Aon Cocubes	Bharat Earth Mover Limited	Caterpillar India Pvt. Ltd
Aon Consulting	Bharat Heavy Electricals Limited	Cavincare
Apar Technologies		Cavinkare Pvt. Ltd.
Apex Fund Services LLP		CBRE
Apna Time Tech Pvt. Ltd.		C-Camp
		CDK Global

CEAT Limited	Dalisoft Technologies Pvt. Ltd	Epiroc Mining India Ltd
Ceasefire Industries Pvt. Ltd.	Danieli India Ltd.	Ernst & Young - India
Central Coalfields (CCL)	Datacare Systems	Evolvute Group
Chai Point	Datamark	Exalca Technologies Pvt. Ltd.
Chambers of Adv. Avneesh Arputam	Deal Money Securities Pvt Ltd	Executive Access
Chambers of Adv. Biswajit Sarkar	Decathlon Sports India Pvt Ltd.	Exela Technologies
Chinar Realty Pvt. Ltd.	Defence Avionics Research Establishment	Expanrr
Chittaranjan Locomotive Works	Delhi Dispute Resolution Society	Exposys Data Labs
Choice Equity Broking Pvt. Ltd.	Deloitte	Extramarks Education India Pvt Ltd
Choice Securities Ltd.	Delphi TVS	EY GDS
Cholamandal IP	Deltax	FactSet Systems India Private Limited
Chola MS General Insurance Company Limited	Design Esthetics	Fairfield By Marriott
Cholamandalam Investment and Finance Company Ltd.	DHL International	Fame Technologies
Cicon Engineering	Dhyey Consulting Services Pvt. Ltd.	Fanuc India Private Limited
Cisco	Diagnal Technologies	Fastenes And Alliaed Product Pvt Ltd
Classklap Pvt Ltd	Digilabs Consulting	FCB Ulka
Cleartax	Dimo Casting Pvt. Ltd.	FCI OEN Connectors Ltd.
Cloudthing	Disha Communication	Federal Bank
CM Mohammed Iquabal Pvt. Ltd.	District Court of Agra	Financial Software & Systems (P) Ltd
Coal India Limited.	District Legal Service Authority	Fincare Small Finance Bank Ltd
Coca-Cola Ltd.	Dodla Dairy Ltd.	Finastra Software Pvt Ltd
Cochin Shipyard Limited	DRDO	FIS Global
Codechef	Dreamgains Financials India Pvt. Ltd.	Flipkart
Codenation Innovation Labs (CNIL)	DTDC	Flowserve Microfinish Pvt. Ltd.
Coffee Day Beverages	Dynotech Instruments	Flowserve Micro Finish Pvt. Ltd.
Cognizant	Dyson Technology India Private Limited.	Focus Academy For Career Enhancement (FACE)
Collins Aerospace (UTC Aerospace Systems)	E4 Development and Coaching Limited	Fore Vision
Commvault Systems (India) Private Limited	E4 India (Forbes Facility)	Fresh Paprika
Company Law Bhavan	Earnwealth Solutions Pvt. Ltd.	Fujitsu Consulting India Pvt. Ltd.
Competition Commission of India	East India Exim	Fundtaxguru
Connectecho Talent Labs	Eazydiner Pvt. Ltd.	Future Businesstech India Pvt. Ltd.
Continental Automotive Components India Pvt. Ltd	ECIL	Future Generali India Life Insurance Company Limited
Copyright Integrity International	Edumpus.Com	Gagan Project Pvt. Ltd.
Coreel Technologies	Edventus	GAIL India Ltd.
Cosmo Vision	Edyoda (Zekelabs Technologies Pvt. Ltd.)	Gati Limited
Cosmonet Solutions Pvt. Ltd.	Effectual Services	Gboxz Technologies Pvt. Ltd.
Counselence	EIPOC Pvt. Ltd.	GE Corporate
Credr (Incredible Technologies Pvt. Ltd.)	Electronics Corporation of India Limited	Geebee Education
Criticalog India Pvt. Ltd.	Empro Plant	General Aeronautics, IISC
CRMIT Solutions Pvt. Ltd.	Endurance International Group	Gensuite
Crossbow Labs	Enerman Technologies	Getmyuni
CSIR - NAL	Engine Division-Hindustan Aeronautics Limited	GlaxoSmithKline Consumer Healthcare Ltd
Cuemath	Enquero	Global Edge Software
Cyient	Investnet Yodlee	GM Infinite Dwelling India Pvt. Ltd.
DBS Bank	Envision Financial Systems	Godrej & Boyce Mfg. Co. Ltd.
D. Sarupriya & Co.	EPAM Systems, Inc.	GoKare LPO Pvt. Ltd.

Goldman Sachs	Homelane.Com	JW Marriott
Gomechanic	Honeywell	Jain University
Goodyear India Ltd	Housejoy	Jamakhandi Sugars Pvt. Ltd.
Great Learning	HP India	Jamkash Vehicleades Kashmir Pvt. Ltd., Srinagar
Grexter	Human Rights Law Network	Jammu And Kashmir Bank
Growup Technologies Pvt. Ltd.	Hawkins Cookers Limited	Jaro Education
Gulabs	Hygienic Research Institute Pvt. Ltd.	Jet Aerospace Aviation Research Centre
Gyan Matrix Technologies	Hyundai KC Srinagar	Jiyo Fullest
Hakke Industries Pvt Ltd	Hyva IT Solutions Pvt. Ltd.	Jmarathon Advisory Pvt. Ltd.
HAL - Helicopter Division	iBroad 7 Communication	Josh Technology
Haldirams	IBM	Joulestowatts Business Solutions Pvt. Ltd.
Hanu Software	IBS Software (P) Ltd	Joy'S Interior Solutions
Happilo International Pvt. Ltd.	ICICI Bank	Jsk Industries Pvt. Ltd.
Harman International	ICICI Prudential Life Insurance	JSW Steel Ltd.
Harman Connected Services	IDBI Federal Life Insurance Co. Ltd.	Judicial Tamilnadu Service
Harpreet Ford	IDFC First Bank	Jumbotail Technologies Pvt. Ltd.
Hashedin Technologies	Idisha Info Labs Pvt. Ltd.	Justice Mrs. Sangita Dhinghra Sehgal, Delhi High Court
Hatsun Agro Product Ltd.	IHS Markit	JUSPAY Technology Private Limited.
Hatsun Pvt. Ltd.	IIFL Securities Ltd.	Kaar Technologies
HCL Technologies Ltd.	ILC Group of Industries	Kaleyra
HDFC Asset Management Company (HDFC AMC)	IM Solutions	Kantar
HDFC Bank Ltd	InCred	Karnataka Hybrid Micro Devices Limited
HDFC Life	Indegene Private Limited	Karnataka State Habitat Centre
Healthkart	Indian Institute of Management, Bangalore	Karvy Analytics
Healthplix Technologies	Indian Oil Corporation	Katerra India Pvt. Ltd.
Heavy Engineering Corporation Ltd	Indian Talent Olympiad	Katerra India Pvt Ltd
Hedge Group of Companies	Indo Thai Management Services Pvt. Ltd.	Kauvery Hospital
Hedge School of Applied Economics	Indus Law, Bangalore	Keerthi Agro Mills Pvt. Ltd.
Helicopter Division - Hindustan Aeronautics Limited	Indusind Bank	Keltron (Kerala State Electronics Development Corporation Ltd.)
Heritage Food	Infosys Ltd	Keltron Controls
Hershey India	Infiniti Research	Kempegowda International Airport Bengaluru
Hescom (Hubli Electricity Supply Company Ltd)	Innointel Global Pvt Ltd	Kennametal India Limited
Hewlett Packard Enterprise India Private Limited (HPE)	Inovatree	Kent RO Systems Ltd.
Hexaview Technologies	Instalane	Kerala Gandhi Smarak Nidhi
Hexaware Technologies Limited	Institute of Legislative Drafting and Research	Kerala Institute of Medical Sciences (KIMS)
HICAL Technologies	Insurance Regulatory and Development Authority of India	Ketron Controls
High Court of Karnataka	Intellectual Property Rights Attorney Association	Keystone Partners
High Peak Software	Intellipaat	Khan Constructions Pvt Ltd
Hike Education	International Method United Nation	Khimji Ramdas
Himatsingka Seide Ltd.	Interviewkickstart	Klaritylaw
Hinduja Global Solutions	Investosure	KMS Engineering Ankur Air Products Pvt. Ltd.
Hindustan Aeronautics Limited	IPexcel Services Pvt. Ltd.	Kochhar & Co.
Hindustan Coca Cola Beverages Pvt. Ltd.	ITC Limited	Kongtronics Pvt. Ltd.
Hindustan Unilever Limited	ITW Consulting	Kontresind Consulting Pvt. Ltd.
Hitachi Rail STS India Pvt. Ltd.	Ivy Mobility Solutions Private Limited.	
Home First Finance Company		

Kore.ai Software India Pvt Ltd	Medanta The Medicity	New Consolidated Construction Co. Ltd.
Korea Trade Office Bengaluru (KOTRA)	Medopharma	New Delhi Law Offices (NDLO)
Korn Ferry	Meet University	Next Legal Services
Kotak Life	Mento Associates	Ninestars Information Technologies Pvt. Ltd.
Kotak Mahindra Bank	Meraki Wholesale Trading LLC	Ninjacart
KPIT Technologies Ltd.	Mercer Consulting	Niranjan & Associates
KPMG	Metal Profiles	NJ India Invest Pvt. Ltd.
KPR Advocate Office	Metlife PNB India Ltd.	Nobroker Technologies Pvt. Ltd.
KPTCL	MetricStream	Nopaperforms Solutions Pvt. Ltd.
Kreator3D	Microland Limited	Northeast Small Finance Bank Ltd.
Kreeda Online Services (OPC) Pvt. Ltd.	Micron Ems Tech Pvt. Ltd.	Novel Office
KSA Enterprises	Milan Laboratories Limited	NRG & Co.
KTAB Technological Pvt. Ltd.	Milople	NS Associates
L&T Construction	Ministry of Labour & Employment	NSKT & Co.
L&T Metro Rail (Hyderabad) Limited	Ministry of Law and Justice	NTT Data
L&T Technology Services Limited	Mint Wealth Management	Odessa Technologies
Laalsa Business Insights Pvt. Ltd.	Mistay Hospitality Pvt. Ltd.	Odisha State Commission for Women
Lakshmivan Polymers Pvt. Ltd.	Moody's Analytics (India) Private Limited	Off Hands Digital Solutions Pvt. Ltd.
Landmark Group	Monocept	Olectra Greentech Limited
Larsen & Toubro Limited	Motilal Oswal Financial Services Limited	Oligosoft Corporation
LawSikho	Moxtra Solutions Pvt. Ltd.	Omax
Leadsquared	MP State Legal Services Authority	Oneassist Consumer Solutions Pvt. Ltd.
Lido Learning	MS Advisory	ONGC
Linc Pen & Plastics Ltd.	MSFM Fiat Justitia LLP	Onnet Systems India Pvt. Ltd.
LinkCXO	Muneer Cars	Onsurety Technologies
Lobotus Technology Pvt. Ltd.	MVM Solar Pvt. Ltd.	Opentext
Logiclog Logistics	My First Boss	OPPO
Lokayukta Office, Karnataka	Mygate.com	Oracle Corporation
Loreal India Pvt Ltd	MZM Legal, Mumbai	Oravel Stays Pvt. Ltd.
Fox & Mandal	Nagarro Software	Org Tree (Kiru Brand)
Lakshmiwan Polymers Pvt. Ltd.	Nalco Ltd.	Orient Cement
Maersk	Nascens (Happa Foods)	Oyedesi Pvt. Ltd.
Magma FinCorp	National Commission for Women	Panicker & Panicker Advocates
Mahanadi Coal Field Limited	National Human Rights Commission	Paramatrix Technologies Pvt. Ltd.
Mahendra Group of Companies	National Institute of Engineering	Park Plus
Mahindra Electric Mobility Ltd	National Instruments India Private Limited.	Parle
Mahindra Finance	National Judicial Academy, India	Patna High Court
Mahindra Reva	National Thermal Power Corporation Ltd. (NTPCL)	Pavan Duggal Associates
Mangalore Refinery and Petrochemicals Limited	Natural Remedies Pvt. Ltd.	PayPal
Manipal Cigna	Naukri.com	Paytm
Manipur Tribal Development Corporation Ltd.	Navayuga Engineering Company	Peacock Solar
Marathon Group	Navson Technologies	Phable Care
Marriott-Renaissance	Naya Raipur Development Authority (NRDA)	Phonepe
Maruti Suzuki	Nayagaadi.Com	Piaggio Vehicles Pvt. Ltd.
Matrixcare India Pvt. Ltd.	NCR Corporation	Pin Click Property Management Pvt. Ltd.
Maveric Systems	Nestle (Nestlé India)	Pinakin Wealth Management
Max Life Insurance Co. Ltd.	Netapp	Pinkblue Pvt. Ltd.
Mea Ame		

Piramal Enterprises Limited	Reliance Jio Infocomm Limited	Skymetweather Ltd.
Planetspark	Reliance Nippon Life Company Limited	SME Corner
Plasmagen Biosciences (P) Ltd.	Reliance Retail Ltd. (Footprint)	Smergers
PMJ Constructions Pvt. Ltd.	Renaissance-Marriott	Smrithi Foundation
Poddar Car World Pvt. Ltd.	Rendus Technologies	SN Associates
Poornam Info Vision Pvt Ltd	Rentospot India Pvt. Ltd.	Sobha Limited
Power Grid Corporation of India Limited	Response Informatics Ltd.	Social DNA
Pramata Knowledge Solutions Pvt. Ltd.	Ricago Pvt Co. Ltd.	Sollys Consulting and Solutions Pvt. Ltd.
Pratidin Time	Ricoh India Ltd.	SOLV
Pride Pristine Law Associates	Roxy Roller Flour Mills (P) Ltd.	Solve Foundation
Primenumbers Technologies	Royal Sundaram General Insurance	Sonata Software Ltd.
Pristyn Care	rtCamp Solutions Private Limited.	Sophia Constructions
Private Chamber	Ruchita Sannathi Law Associates	South Central Railway WWO
Priyanka Automotives	Rudra Law Firm	Sowing Bean India Pvt. Ltd.
Profound Legal Services	S&P Global	Spectrum Legal
Propdial	S&S Associates	Spice Route Legal
Prudential Infotech Limited	Sahajanand Laser Technology Limited	SPI Cinemas
Puravankara Projects Limited	Sahjanand Laser Technology Ltd.	Spottabl
Psyteach Digi Pvt. Ltd.	Sai Sankalp Beverages	Square Yards
Publicis Sapient	Saint Gobain	Sri Sai Technologies
Pulse Secure Technologies (India) Pvt. Ltd.	Salesforce	Standard Chartered Global Business Services Private Limited
Puma Lift Trucks Pvt. Ltd.	Samarthanam Trust for the Disabled	Stanza Living
Punjab State Human Rights Commission	Sanguine Capital	Starfing Pvt. Ltd.
Purple Quarter	Sanpar Industries Pvt. Ltd.	Startup Clubs Pvt. Ltd.
Purplepath	Sansera India Ltd.	State Consumer Dispute Redressal Forum
PwC	Sasken Technologies Limited	Stratemis HR Technology
Qogent Learning Solutions	Satguru Travel	Straus Institute of Dispute Resolution
QTPI Robotics Pvt. Ltd.	Savex Technologies	Studymode Technologies Pvt. Ltd. (Barnes & Noble Education)
Quadgen Wireless Solutions Pvt. Ltd.	SBI Caps Securities Ltd.	Stumpp Schuele & Somappa Springs Pvt. Ltd.
Quest Global	SBI Funds Management Pvt. Ltd.	SUBEX
Quick Ride	SBI Life	Sundarswamy & Ramdas Advocates
R.D.B Legend	Schneider Electric Ltd.	Suphalaam Technologies Pvt Ltd
Rail Wheel Factory	Sebastian & Co.	Supreme
Rajagiri Hospital	Shakti Precision Components Pvt. Ltd.	Svnit Surat
Rajbhoomi Global Investment Ltd.	Shapoorji Pallonji Company Pvt. Ltd.	Synchronoss Technologies
Rao IIT Academy	Shilpa Sharad & Co.	Syncron Services India Pvt. Ltd.
Rashtriya Ispat Nigam Limited	Shriram Insight Share Brokers Ltd	Syngene International
Rave Technologies	Shriram Life Insurance	Synlitigators
Razorpay	Shriram General Insurance Company	Synopsys
RDCIS-Sail	Shunyata Learning Pvt. Ltd.	Syntegon Technology India Pvt. Ltd.
Realbridge E-Marketing Solutions Pvt. Ltd.	Sibo Shankar Mishra And Associates	TK Engineering Consortium Pvt. Ltd.
Reelo	Signify	Taj Hotel & Convention Centre
Relaso Enterprise Software Pvt. Ltd.	Simplilearn.Com	Tankha Associates
Reliance Ecommerce - Fashion & Lifestyle	Sizzle Properties Pvt Ltd	
Reliance Footprints	Skill Santa	
Reliance Industries Ltd.	Skydream Consulting	

Target Corporation	TSync Technologies	Wipro Lighting
Tata Advanced Materials. Ltd.	TTK Prestige Ltd.	Wipro Limited
Tata Aerospace	Tudip Technologies Pvt. Ltd.	Wipro Ltd.
Tata AIG General Insurance Co.	Tvs Credit Services Ltd.	Wipro Consumer Care & Lighting (WCCLG)
Tata Consultancy Services (TCS)	Tygar Law Corporate	WNS
Tata Consulting Engineers Limited	UAS International	Wooqer
Tata Electronics Private Limited	Ultimate Wealth Managers (P) Ltd.	Wynad Exports
Tata Power Solar Systems Ltd.	Ultratech Cements Ltd	XL Dynamics India Pvt. Ltd.
Tavant	Ultria Software Pvt. Ltd.	Xpress Minds Edutainment Pvt. Ltd.
Tax Chamber	Uma Arya Law Office	Yellow Messenger
TBA Lawyers	Unacademy	Yes Bank
Tech Fortune Technologies	Union Bank of India	Yuken India Ltd
Tech Mahindra Limited	Unisys	Zara
Techachiever Engg. Pvt. Ltd.	United Lex	Zeta India
Techachiever Engineering Pvt. Ltd.	Usha Martin	Zinnov Management Consulting Pvt. Ltd.
Techciti Technologies Pvt. Ltd.	UTI Asset Management Co. Ltd.	Ziroh Labs Pvt. Ltd.
Techolution	Vadilal Industries Ltd.	Zomato
Techshot Imagine Pvt. Ltd.	Valeo India Pvt. Ltd.	Zunroof Tech Pvt. Ltd.
TEKsystems Global Services	Valorem Stack Pvt. Ltd. (Flobiz)	Zuri Group Global
Terumo Penpol	Vansh Constructions Pvt Ltd	Zycus Infotech Pvt. Ltd.
THDC India Ltd.	Vardhan Consulting Engineers	Zykosoftware Technologie
The Bluebeans	Varun Beverages Limited	
The Hackett Group (India) Ltd.	VE Commercial Vehicles Limited	
The Karur Vysya Bank	Vedantu Innovations	
The Leading Solutions	Velocita Brand Consultants Pvt. Ltd.	
The Money Roller	Vera Solutions	
The National Institute of Engineering	Verzeo	
The New Indian Express	Vidharbha Irrigation System Pvt Ltd.	
The Outlook Group (News Magazine)	Vidwaan (by Simapt)	
The RASICH Group	Vijayakant Dairy and Food Products Ltd.	
The Strategist	Vijayanagara Srikrishnadevaraya University Bellary	
Think Vidya Learning Pvt. Ltd.	Vinyas Innovative Technoloigies Pvt. Ltd	
Third Wave Exim	Virtusa Corporation	
Thoughtworks Technologies India Pvt. Ltd.	Virtual Employee Pvt. Ltd.	
TIL Ltd.	Vitvaraa Electronics Pvt. Ltd.	
Times of India	Volano Entertainment Pvt. Ltd.	
Titan Company Limited	Volvo Trucks	
Tk India Pvt. Ltd.	Volvo Group India Private Limited.	
Toppr Technologies	Wallstreet Advisory	
Toppscholars	Waterscience	
Total Enviroment	Wave Infratech	
Total Productions Pvt. Ltd.	We Are Crazy.Org	
Toyada Gosei South India Pvt. Ltd.	Wellversed	
Toyota Industries Engine India Pvt. Ltd.	West Agile Labs	
Toyotetsu India Private Ltd.	Westraj Gum Udhyog	
TravelXP TV	Whitehat Jr.	
Trespect	Winjit Technologies	
Tripura High Court		
Truecaller		

ALLIANCE ALUMNI ASSOCIATION

Core Committee Members:

Prof. Mihir Das Associate Professor & Interim Associate Dean Alliance School of Applied Mathematics	Chairperson
Dr. Ramanna Shetty Professor & Director - Alliance Ascent College	Member
Prof. Devaiah N.G Assistant Professor - Alliance School of Law	Member
Dr. Ashwathaman H Assistant Professor - Alliance College of Engineering and Design	Member
Dr. Thangjam Ravichandra Singh Assistant Professor & Deputy Director - Alliance Ascent College	Member
Prof. Arunabhas Bose Assistant Professor & Program Director - Executive PGDM - Alliance School of Business	Member
Ms. Surekha Shetty Sr. Director - Alumni Relations	Member

Webinar - Digitizing a Business - Industry Best Practices

SPEAKERS

DR. RAY TITUS
Professor & Dean
Alliance School of Business
Alliance University

MR. TONY V. FRANCIS
National Head - Specialist Unit
Matrix Publicities, WPP
MBA, 1999 - 2001

MR. RAMAKANT RATHORE
Client Partner
Caggemini Technology Services India Limited
PGDM, 2004 - 2006

***Alliance Alumni Association organized an interactive webinar for the students and alumni on January 7, 2021,
Topic of the Webinar: Digitizing a Business - Industry Best Practices***

Webinar - Embracing Fintech Disruptions in the Banking and Financial Service Industry

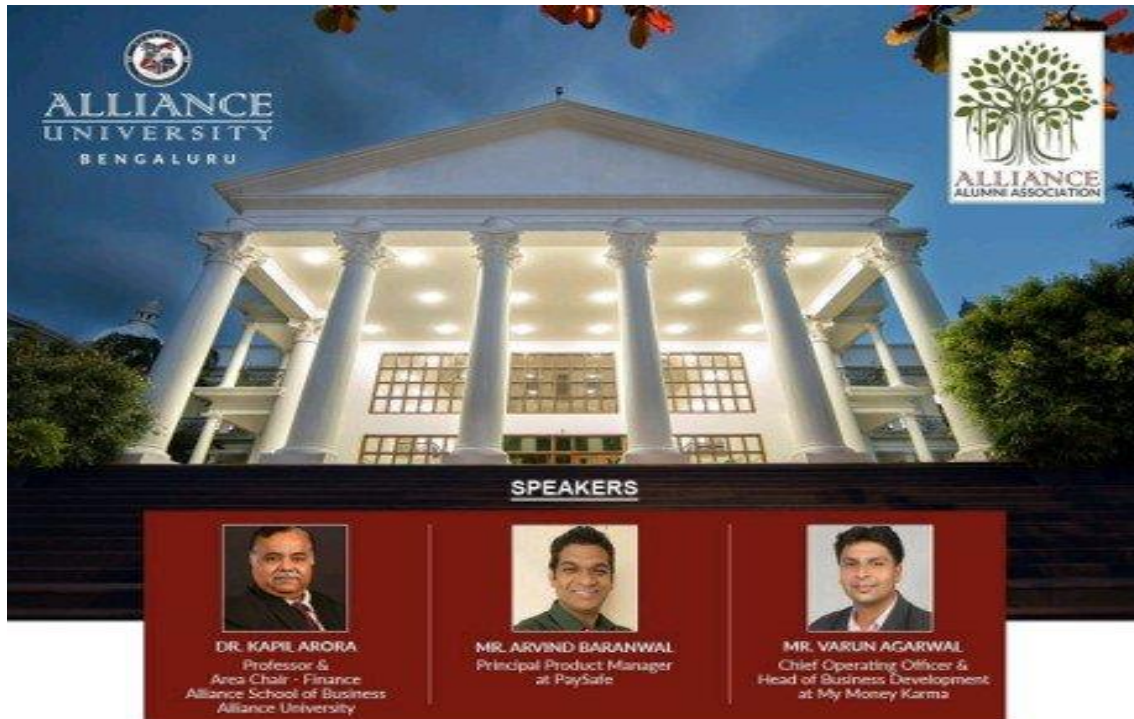

Alliance Alumni Association has organized an interactive webinar for the students and alumni on February 4, 2021

Topic: Embracing Fintech Disruptions in the Banking and Financial Service Industry

Session on Specialization Briefing

 <p>Mr. Vishwanath Raju Head - India Talent Acquisition Dun & Bradstreet</p>	 <p>Mr. Aashish Thakur Director - Projects Cognizant</p>	 <p>Mr. Rishi K. Associate Director Cushman & Wakefield</p>	<p>Date: March 20, 2021</p> <p>Time: 10:15 am - 04:30 pm</p> <p>Dress Code: Business Formals</p> <p>Venue: Seminar Hall 1 (Learning Center - 1st Floor)</p> <p>www.alliance.edu.in</p>
 <p>Mr. Shankar Shivakumar Associate Director Acuity Knowledge Partners (Moody's Analytics)</p>	 <p>Ms. Tanvi Thacker Head - Employee Benefits Infosys</p>	 <p>Dr. Ray Titus Pro Vice-Chancellor (Academics and Research) Alliance University</p>	

This session helped the students to understand the career growth, the opportunities available in the job market and the importance of choosing a specialisation in their MBA program

Webinar Series

Date	Alumni Name	Designation
January 07,2021	Mr. Tony V. Francis and Mr. Ramakant Rathore	National Head Specialist Team – Matrix Publicities, WPP and Client Partner at Capgemini
February 04,2021	Mr. Varun Agarwal	Chief Operating Officer & Head of Business Development at My Money Karma
March 20, 2021	Ms. Tanvi Thacker	Head-Employee Benefits at Infosys
June 05, 2021	Mr. Naren Shetty	State Head at PhonePe

Alumni Interactive Session 2021

Date	Alumni Name	Designation	Topic
March 11, 2021	Mr. Saugata Sengupta	Director of Avasant	How to Plan Career in Technology, Research, & Consulting
March 18, 2021	Mr. Benjin Samuel	Global Sourcing and Recruitment at Tata Consultancy Services	Shift in Industry Hiring Trends-2021
March 25, 2021	Mr. Iftakhar Asfi	Director Business and Strategy Saudi German Hospitals Group - Dubai, UAE	Young Business and Leadership Roles - Opportunities and Challengers
April 1, 2021	Mr. Sreejith Krishan	Head-Learning and Development Centre, Sony India Software Centre	Skills that Matter-Key Behavioral Competencies Important for Career Success
April 7, 2021	Mr. Anirban Dutta	Assistant Vice President Model Risk Audit, HSBC	Dialogue in the Dark-How a management education can help professionals to accept challenges that are yet unknown?

Date	Alumni Name	Designation	Topic
April 17, 2021	Mr. Sahil Kapoor	Associate Vice President (Fixed Income Middle Office), JP Morgan & Chase Co.	Open Discussion – Career Choices, Surviving and Thriving in Corporate Culture, Work from Home Challenges and Benefits
May 1, 2021	Mr. Vineet Patil	Chief of Business VOIZ & Co-Founder of Laundrokart.com	Opportunities in Entrepreneurship
May 14, 2021	Mr. Ramakant Rathore	Client Partner at Capgemini	Remote learning & Work: Onboarding from Home
May 21, 2021	Mr. Dipanjan Naha	Director and India Lead GTM for Global Financial Services at Deloitte	FS (Financial Services) GIC & Emerging Trends
May 21, 2021	Mr. Karthik. B. Murthy	Legal Retainer at Titan Company Ltd.	LAW School, Corporate Job and Experiences - My Journey
May 22, 2021	Deepti Gupta	Director HR at Dream 11	What after an MBA? Start-up or an MNC?
May 29, 2021	Mr. Tony V Francis	National Head Specialist Team – Matrix Publicities, WPP	Work Life Balance in the Corporate Work - Truth or Myth?
June 1, 2021	Mr. Harish T V N	Associate Vice President and Head Commercial Operations – Mylan Indonesia	Work Life Balance in the Corporate Work - Truth or Myth?
June 5, 2021	Mr. Prashanth Bangalore	Technical Program Manager at Google	A Career in Program Management
June 1, 2021	Mr. Anand Toshniwal	Lead Analyst Boston Consulting Group	Transition from Campus to Corporate

Date	Alumni Name	Designation	Topic
June 5, 2021	Ms. Sakshi Joshi	Procurement Category Lead at Lowe's India	The Power of Communication
June 5, 2021	Mr. Shyam Surianarayan	VP, Pricing & Revenue Enablement at S&P Global Market Intelligence, USA	Changing Dynamics of Customer Value Creation
June 12, 2021	Mr. Debjan Bhowmik	Human Resources Manager at BDO in India	Keep Self Motivated in the time of Pandemic
June 12, 2021	Mr. Gagan Deep Khosla	Accenture Analytics Innovation – Principal at Accenture	Augmented Intelligence (AI) for Business Leaders
June 19, 2021	Mr. Ashish Garg	National Retail Head at Indo-Asian at Legrand (India)	Emerging Trends in Retail Space
June 19, 2021	Mr. Siddharth Somani	Global Webinar Execution Specialist at NetApp	Job Description', under the JD discussion series
June 19, 2021	Dr. Priyanka Shrivastava	Senior Lecturer, Marketing at University of Singapore	New Age Marketing
June 24, 2021	Mr. Kiran Kumar	Associate Director Acuity Knowledge Partners	Overview of Investment Banking
June 25, 2021	Ms. Mridula Venugopal	Chief People Officer at MiQ	People-Driven vs. Profit-Driven Organizations

INFORMATION TECHNOLOGY SERVICES

Brief Overview: Alliance University has implemented the IT Network infrastructure and a state of the Unified Communication solution in the University campus with the latest technology that suites the present and future needs of University. Alliance in association with CISCO Systems has built a strong networking and communication infrastructure for both wired and wireless connectivity. The University has implemented the integrated web-based ERP application where all the academic and non-academic functions of the University are automated.

IT Infrastructure at University Campus:

- All the blocks in the campus are interconnected by Fiber Optic cables with a more than one redundant ring topology
- Indoor networking connectivity is established thro CAT 6 which is ideal for supporting 10 Gigabit Ethernet
- A centralized data centre where all the networking and communication controls for the whole University is established and monitored
- Connectivity for Data and Voice on single physical infrastructure
- Each block has a separate hub room where the Cisco CAT 2960 access switches and CAT 3750 distribution switches are installed which is connected to the Core switch CAT 4500 in Data Centre through fibre optic ring forms a three layers architecture with redundancy in each layer
- A 700 MBPS of leased line internet connectivity with active/standby ring topology
- A voice PRI line with 400 direct inward dialing lines
- IP telephony implementations
- All the classrooms, seminar halls, Library area, food court and outdoor open spaces are covered under secured wireless internet access
- Computer Labs with latest configurations desktop machines
- Security implementation is by Cyberoam Next Generation Firewall System
- Intrusion Prevention System (IPS) which monitors University network and system activities for malicious or unwanted behaviour and can react, in real-time, to block or prevent those activities
- Cyberoam Web Security solution is implemented which is an URL filtering application with extensive security capabilities. It minimizes the security threats by applying real time security updates
- All the students have been given a university/institute mail id
- 3000 Sq. ft. of physical area exclusively kept to house Centralized Data Center and IT facilities/offices
- CCTV cameras are installed at key University locations

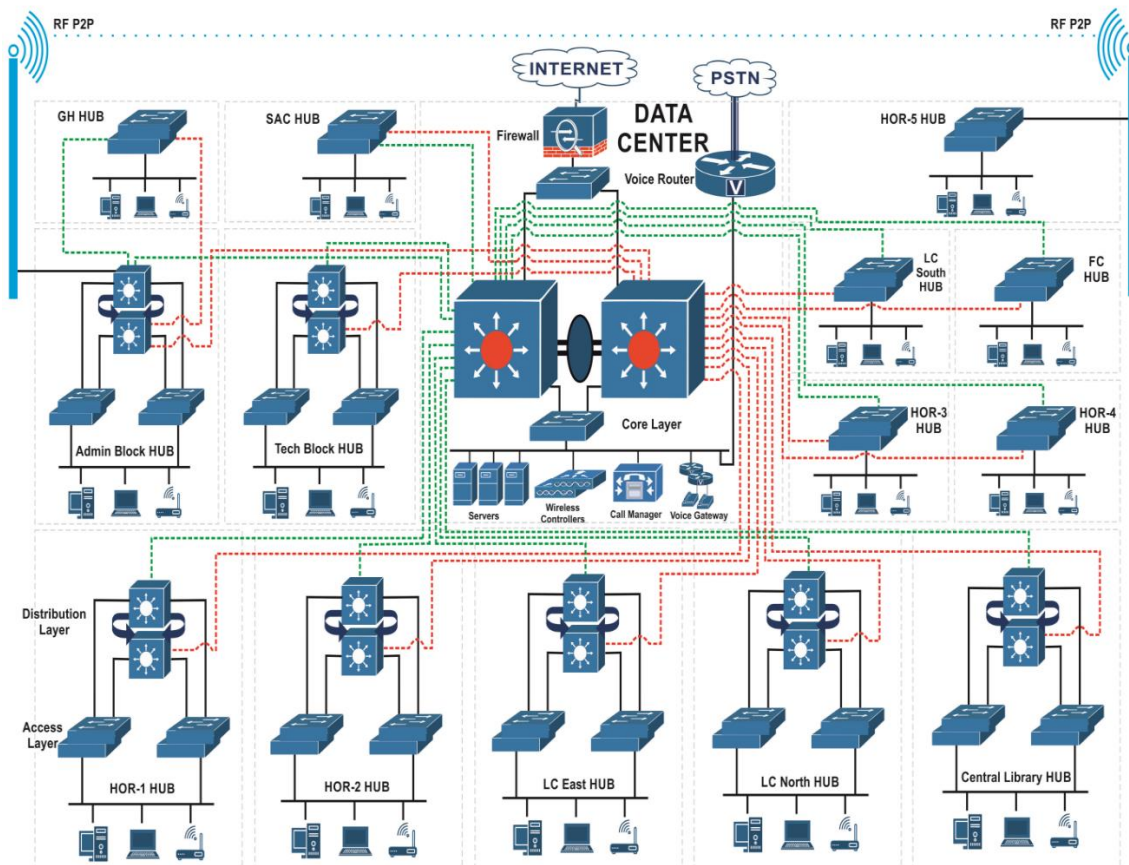
Network Overview:

Department Activities: The Information Technology Services (ITS) department is responsible for the IT infrastructure management in a 24 x 7 environment covering system operations, network operations (data & voice), IT Purchases, IT security and audit, hardware and software of the computers in the University.

1. Desktop support for students, staff and faculty
2. Server support and Maintenance
3. Managing the IT Network Infrastructure and Operations (Data and Voice)
4. Respond to IT issues, hardware maintenance, software, networking, etc.
5. Administer network and data security, including directory, group policy, firewalls, virus protection, and email security
6. Managing Inventory which involves master inventory document control
7. Use of technology to enhance, expand and expedite the services utilized by students, faculty, and staff.
8. Provide appropriate and adequate technology support to all faculty and staff to support academic program objectives.

9. Helping all University stake holders to understand the utility, cost, risk and future of the technology
10. Co-ordinating with the various departments in the organization to ensure that IT operational requirements are efficiently met.
11. Development and maintenance of web-based ERP system
12. Maintenance of Learning Management System
13. Website Development and Maintenance
14. Data backup and Disaster Recovery Management
15. Computer Lab Operations
16. Providing help desk support services to all University stake holders.
17. E Waste Management
18. New IT infrastructure Projects

Updated Systems and Procedures for Utilizing and Maintenance of IT Resources

The Faculty/Staff/Students/Guests of University is provided with computer workstations facility. (Nearly 800 systems)



Cyber Security / Data Privacy

Cyber Security is about defending IT Facilities and Services and stored data from unauthorised access, use, disclosure, disruption, modification and destruction. It is concerned with ensuring integrity, availability, confidentiality and safety of data and services and ensures controls are proportionate to risk.

The University recognizes the importance of Cyber security. It is committed to ensuring all University activities involving information technology are appropriately defended against Cyber security threats.

The University recognizes that successful implementation of Cyber security relies on having a well-informed user community combined with effective management procedures.

University ERP and Digitization:

The most of the academic and non-academic functions of the University are automated and during the academic year 2020- 21 many new enhancements and new features were released.

The following modules/functionalities are implemented and are currently live.

- Admission Module
- Office of the Registrar
- Fee Module
- Academic Administration
- Hostel Management
- Exam Module
- Employee Module
- Student Module
- Admissions - NPF
- Can - Superset
- Alumni Relations – VAAVE.COM
- Library – KOHA
- Finance & Accounts – TALLY ERP
- Relyon Saral TDS
- Relyon Pay Pack

Microsoft Teams

Alliance University has implemented Microsoft Teams which is a unified communication and collaboration platform which also has a feature like document sharing and online meeting. During the COVID 19 pandemic, the University has seamlessly moved all its academic activities to virtual mode mainly using Microsoft Teams.

New Initiatives:

The department of ITS has initiated series of new initiatives in terms of upgrading the core IT infrastructure and towards the implementation of information & communication technology in the University. The few of the initiatives are listed below.

1. After reopening of the education institutions post COVID, the University has implemented hybrid learning mode of teaching by integrating available EdTech platforms with classroom audio visual system.
2. Currently the system is designed in such a way in all the classrooms that the teachers can switch over from online mode of teaching to hybrid mode or vice versa seamlessly at any given point of time.
3. The University firewall security system is upgraded with Sophos XG system at the perimeter level to mitigate threats arising from the outside network (Internet) as well from the inside network (LAN).
4. The effective back up of the standalone system data in the cloud is implemented.
5. The distribution layer switches in the three-layer network architecture are upgraded with Catalyst 9300 series switches.
6. The main learning block Wi-fi infrastructure is getting upgraded with latest Cisco Access Points and wireless controllers.
7. The University wide Learning Management System (LMS) across all schools/colleges is planned and the implementation of the same will start soon.
8. The fully equipped studio with acoustic features for recording e learning contents and University branding activities is getting implemented.
9. Initiated the process for implementing the automated Lecture Capture solution in few of the classrooms which will be gradually covered to all the University classrooms.
10. The new enhance hostel management module as part of the digitization of the hostel functions is implemented.
11. The integration of the fee management module of the ERP with the Finance & Accounts Tally ERP is implemented.
12. Many enhanced and new features related to academic and nonacademic functions of the University ERP are released.

Ed-tech initiatives during the pandemic to ensure uninterrupted student learning

Alliance University as part of its endeavour to ensure uninterrupted student learning and engagement during the pandemic launched several Ed-Tech initiatives. A snapshot is as follows:

Coursera for Campus:

Alliance University entered into an amazing collaboration with a world-class digital partner “Coursera for Campus” to offer massive open online courses and certifications to benefit our student community.

Alliance University was highly successful in shifting their learning program online ensuring uninterrupted student learning during the lockdown owing to the pandemic. Alliance University learners logged over 8700 course completions; 75K hours of learning; and over 1000 learners with 4+ course completions.

Coursera Inc. also organized an insightful discussion between Dr. Anubha Singh, Acting Vice-Chancellor and Pro Vice-Chancellor, Alliance University and Mr. Bibin Shivas, Head of Customer Success, APAC, Coursera through a webinar on June 30, 2020.

The key takeaways of the discussion were:

- Best-in-class practices adopted by Alliance University in building an effective Coursera for Campus integrated academic curriculum to maintain continuity in learning for students.
- How Alliance faculty and administrators came together with the University leadership team to offer the right student support system for online learning.

Online Classes through Impartus and MS Teams:

Alliance University partnered with Impartus for its ‘Video Learning Platform: Impartus Live’ for conducting interactive live classes and providing access to on-demand lectures for its students. Through the partnership, the University ensures continuity in student learning through the following robust features:

1. Virtual classroom
2. On-demand platform to view recorded lectures
3. Analytics & Reports
4. Cloud Infrastructure

In addition to Impartus, Team ITS at Alliance University also implemented MS Teams as a unified communication and collaboration platform for online classes and continued learning during the pandemic. With a wide array of features, MS Teams as a platform has been highly successful in ensuring faculty-student interaction and virtual learning with academic rigor continues.

Learning Management System (LMS) – Moodle:

Alliance University has implemented Moodle Learning Management system (LMS) across all schools/colleges of the University. The Moodle LMS is integrated with University ERP portal with a single sign on. The LMS is hosted in dedicated servers at the University data centre.

Moodle is a free and open source LMS with customizable management features which the University will leverage on to offer courses that can be accessed by its student community anytime, anywhere.

Awards:

In the wake of the Covid-19 pandemic, higher education institutes were seeing a massive transformation to ensure that learning continues for students even while they are unable to attend physical classroom sessions. As a solution to assist institutions in evaluating their technological competencies, QS – the global rankings and ratings agency, through its India arm, QS IGAUGE created and curated E-Learning Excellence for Academic Digitisation (E-LEAD) Certification to meet the requirements of a rapidly changing and challenging environment for virtual teaching. The certification with a rigorous methodology is built on audit process, data collection & validation, quality check, peer review, and a final review by domain experts. The “E-LEAD Certification” along with a profile listing on the QS IGAUGE website will support certified institutions in establishing themselves as an equipped entity in dealing with the current situation as well as their future-readiness.

Alliance University has been recognized as one of the pioneers in academic digitization and was certified which was valid from 14 May 2020 to 14 May 2021. It is a matter of immense pride that Alliance University is one among the first twelve institutions being certified throughout the nation. This is testament to the fact that our University has displayed readiness to offer education online, both during and post COVID-19.



STUDENT SUPPORT SERVICES

Total numbers of activities across categories	
Category	No. of Activities
Sports & Wellness	04
Extra-Curricular	39
Total	43

Extra –Curricular Activities:

Date	Event
29 th August 2020	National Sports Day Quiz
23 rd -28 th Feb 2021	Cricket Tournament
17 th -18 th March 2021	Chess Tournament
24 th -25 th March 2021	Badminton Tournament
30 th July 2020	Webinar on Yoga Meditation and Wellbeing
15 th August 2020	Independence Day Celebration
19 th -22 nd October 2020	Jan Andolan Campaign
27 th Oct - 2 nd Nov 2020	Vigilance Awareness Week
31 st October 2020	National Unity Day. Rashtriya Ekta Diwas
26 th November 2020	Slogan Writing Competition
26 th November 2020	Constitution Day
28 th November 2020	Pet Passion Pics- Photography Contest
28 th November 2020	Thank God its Saturday
07 th December 2020	Armed Forces Flag Day
12 th & 26 th Dec 2020	Thank God it's Saturday
14 th December 2020	Alliance Girl Up Club- Inauguration & Event
18 th December 2020	Painting Competition
9 th & 23 rd January 2021	Thank God it's Saturday

Date	Event
12 th January 2021	National Youth Day
24 th January 2021	National Girl Child Day
26 th January 2021	Republic day
11 th February 2021	International Day of Women & Girls in science
12 th February 2021	Singing Contest
13 th & 27 th Feb 2021	Thank God it's Saturday!
21 st February 2021	International Mother Language Day
04 th March 2021	National Safety Day
6 th March 2021	One Day Workshop
08 th March 2021	International Women's Day
12 th & 13 th March 2021	AMCC – Intra- University Debate Competition
9 th March 2021	Thank God it's Saturday
12 th March 2021	Symposium, India's freedom Struggle,
22 nd March 2021	World Water Day
5 th April, 2021	Thank God it's Saturday
15 th April 2021	Painting Competition
24 th April 2021	Thank God it's Saturday
07 th May 2021	World Athletics Day
08 th May 2021	World Red Cross Day
09 th May 2021	Mother's Day
12 th May 2021	International Nurses Day
12 th -13 th May 2021	Intra-ASOL Moot Court Competition
17 th May 2021	Essay Writing Contest
22 nd May 2021	Thank God its Saturday
21 st June 2021	International Day of Yoga

Independence Day – 2020



ALLIANCE UNIVERSITY
*Private University established in Karnataka State by Act No. 34 of year 2010
Recognized by the University Grants Commission (UGC), New Delhi*
BENGALURU

Happy National Sports Day

29th August 2020

An online event for student, faculty and staff
Exciting goodies for the first two correct entries

Sports Quiz **Time: 1PM to 2PM**

National Sports Day – Online Quiz

Vigilance Awareness Week-2020

27th October – 2nd November 2020

As part of the Vigilance Awareness Week, Alliance University had organized the facilitation of an online Integrity pledge on November 02, 2020 for staff, students, and faculty. An online Quiz competition on CVC was also conducted for staff, students, and faculty.

The Central Vigilance Commission (CVC), the apex Integrity Institution of the country observes Vigilance Awareness Week every year.

The Vigilance Awareness Week was based on the theme '**Satark Bharat, Samriddh Bharat**' (Vigilant India, Prosperous India)

All activities were conducted online, keeping in mind social distancing norms and other safety advisories issued by the Government of India /State Government for prevention of COVID Pandemic.

Activities:

Pledge Taking Ceremony

Students, staff, and faculty got together on an online platform to take an Integrity pledge as part of the Vigilance Awareness week activity schedule

Online Quiz competition:

An online quiz competition for students, staff and faculty was held as part of the Vigilance awareness week. Questions were based on Central Vigilance Commission

ALLIANCE UNIVERSITY
Private University established in Karnataka State by Act No.34 of year 2010
Recognized by the University Grants Commission (UGC), New Delhi

Vigilance Awareness Week-2020

27 October to 02 November - 2020

सतर्क भारत समृद्ध भारत
Vigilant India Prosperous India

Online pledge taking ceremony
November 2, 2020 @ 4:30pm

Online Quiz
Date: 02-11-2020
Time: 01:00-02:00 PM

Join us on zoom Meeting ID: 753 861 7439 Password: 291020

Rashtriya Ekta Diwas (National Unity Day) 31st of October, 2020



Constitution Day - 26th November 2020



The Online reading telecast of the preamble by the Hon'ble President of India, Shri Ram Nath Kovind

Slogan Writing Contest 26th November 2021

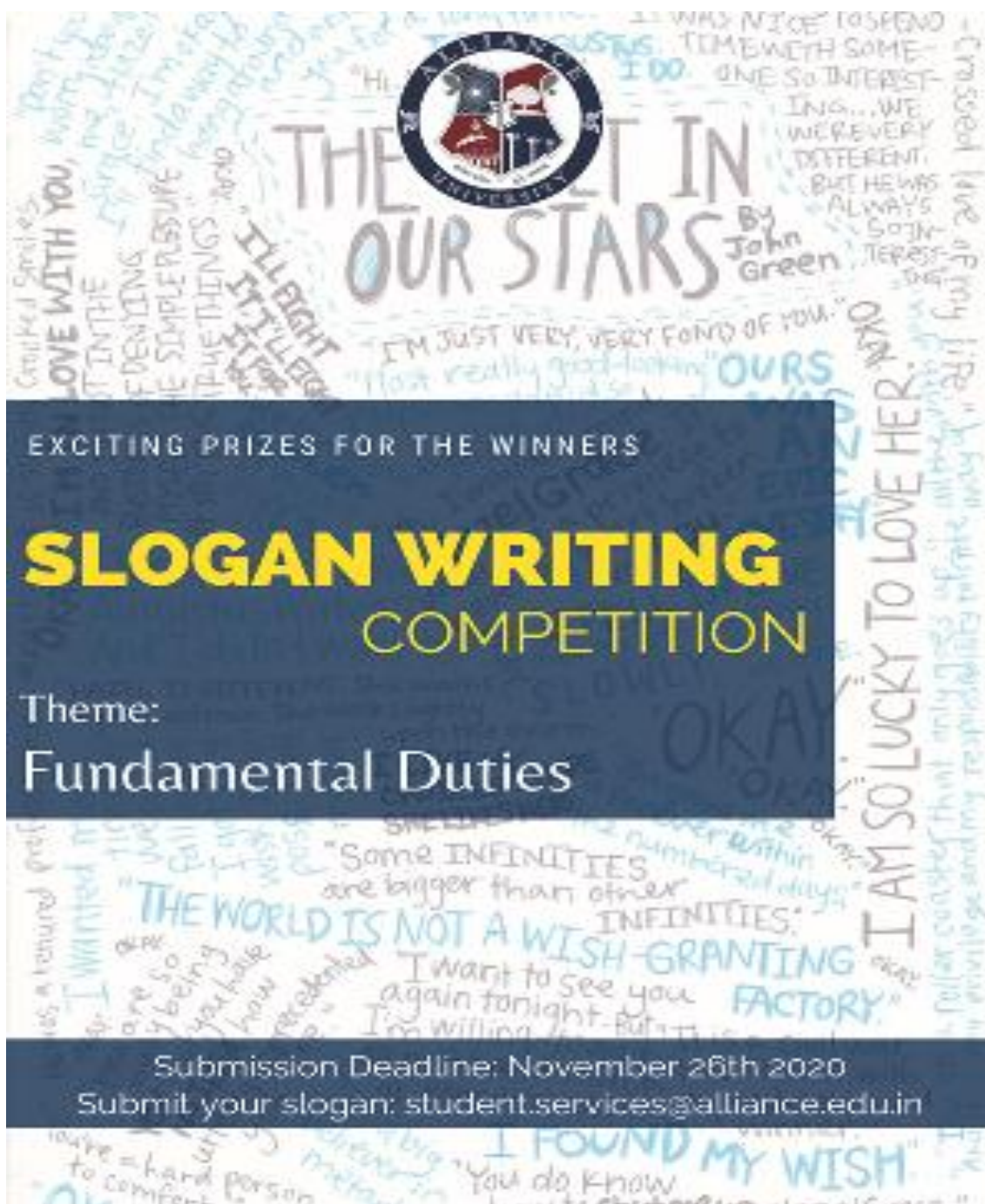

The winning slogan:

“Respect the fundamental rights of the Indian constitution,
Build a prosperous and self-reliant nation”

Photography Contest - 28th November 2020

Pet Passion Pics



“When you photograph people in color, you photograph their clothes. But when you photograph people in Black and white, you photograph their souls!” — Ted Grant

1st Prize – Gautum Tripathi, MBA 2019

Girl Up Club Inauguration 14th December 2020

ALLIANCE UNIVERSITY

INAUGURATION
December 14, 2020
05:30 PM Onwards

INTRODUCTION
To Alliance Girl up Club

DISCUSSION ON
Women empowerment can change the world

UNITING GIRLS TO CHANGE THE WORLD

STUDENT REPRESENTATIVE
MS. VERTIKA ANGRISH
B.B.A. 2018-2021
99513091100



girlUp
ALLIANCE UNIVERSITY

Join us on

Zoom Meeting ID: 7538617439 Password: 291022

Painting Competition - 18th December 2020

Themed Covid-19 - An opportunity for humanity to shine

<p>1st Prize – Ms. Akshiti Singh BTECH 2019</p> 	<p>Ms. Priyadarshini D MBA 2019</p> 	<p>Ms. Arshita Gier MBA 2019</p> 
--	---	---

National Youth Day - 12th January 2021

Topic: 'Role of Youth in Building New India'

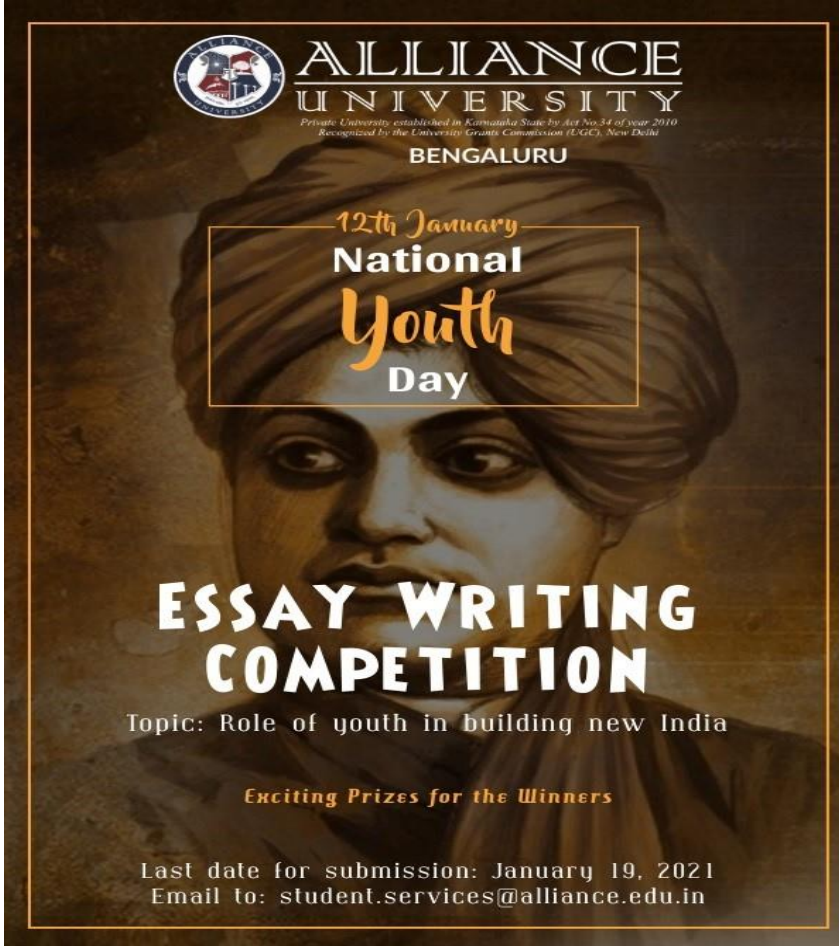

 **ALLIANCE UNIVERSITY**
Private University established in Karnataka State by Act No.34 of year 2010
Recognized by the University Grants Commission (UGC), New Delhi
BENGALURU

12th January
National Youth Day

ESSAY WRITING COMPETITION

Topic: Role of youth in building new India

Exciting Prizes for the Winners

Last date for submission: January 19, 2021
Email to: student.services@alliance.edu.in

National Girl Child Day - 24th January 2021

Theme: 'Girl Child- A pillar of society'

Priya Darshini - ASOB



PriyaDarshini S-ACED



Melbin Joseph - ACED



Republic Day Celebrations



International Day of Women & Girls in science - 11th February 2021

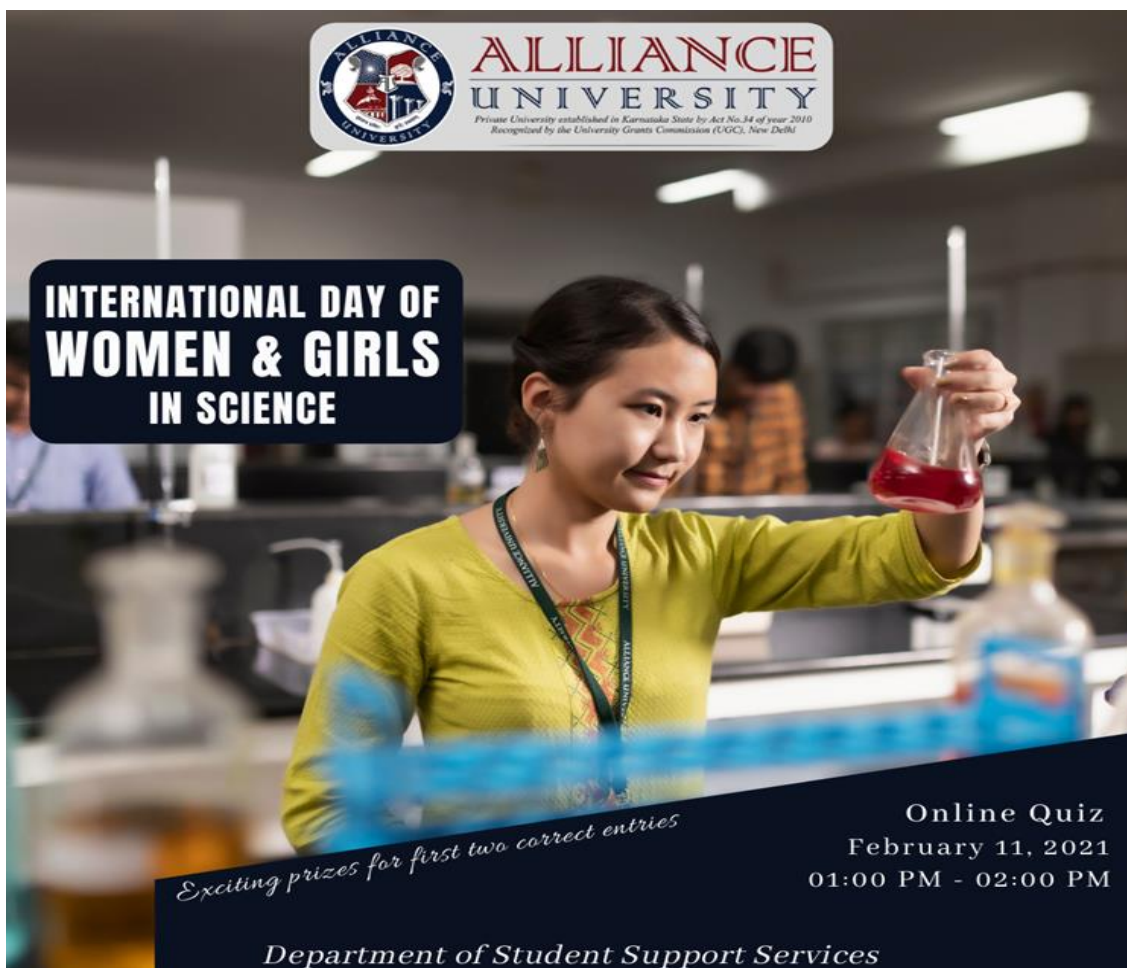

ALLIANCE UNIVERSITY
Private University established in Karnataka State by Act No.34 of year 2010
Recognized by the University Grants Commission (UGC), New Delhi

INTERNATIONAL DAY OF WOMEN & GIRLS IN SCIENCE

Exciting prizes for first two correct entries

Online Quiz
February 11, 2021
01:00 PM - 02:00 PM

Department of Student Support Services

Cricket Tournament - 23rd-28th February 2021



National Safety Day - 04th March 2021



International Women's Day - 08th March 2021



Intra- University Debate Competition - 12th-13th March 2021



Symposium on India's freedom Struggle - 12th March 2021



Chess Tournament - 17th -18th March 2021



World Water Day 22nd March 2021

 **ALLIANCE UNIVERSITY**
Private University established in Karnataka State by Act No. 34 of year 2010
Recognized by the University Grants Commission (UGC), New Delhi

**TOGETHER WE CAN
SAVE WATER**

**WATER
DAY**

AWARENESS

22ND MARCH, 2021
Every drop counts, so dont waste water.
Save Water, Save World.

04:30 PM
Together we can save water

ACTIVITY CENTRE
Join us to celebrate World Water Day and
participate in a rapid-fire quiz competition

Department of Student Support Services

Badminton Tournament - 24th -25th March 2021



Girls Winner Pranathi Karuturi in Action



Dr V.S Patial with the winner Kantheti Surya Vihari

Painting Contest - 15th April 2021

Theme: "Making India Proud-Accomplishments since 1947".



 **ALLIANCE UNIVERSITY**
Private University established in Karnataka State by Act No.34 of year 2010
Recognized by the University Grants Commission (UGC), New Delhi

India's 75 Years of Independence

PAINTING
COMPETITION

THEME Making India Proud
'Accomplishments since 1947'

Submit by: 26, April
@
student.services@alliance.edu.in

Department of Student Support Services

International Inter-School Debate Competition

International Inter-School Debate Competition was Conducted on 19.04.2021, 20.04.2021, 21.04.2021, 23.04.2021.

This series of debate had 66 schools and over 200 students participating out of which 19 schools and 72 students were from overseas and 47 schools and 128 students from India.



International Inter-School Debate Competition for Undergraduate programs – 2021

World Athletics Day - 07th May 2021

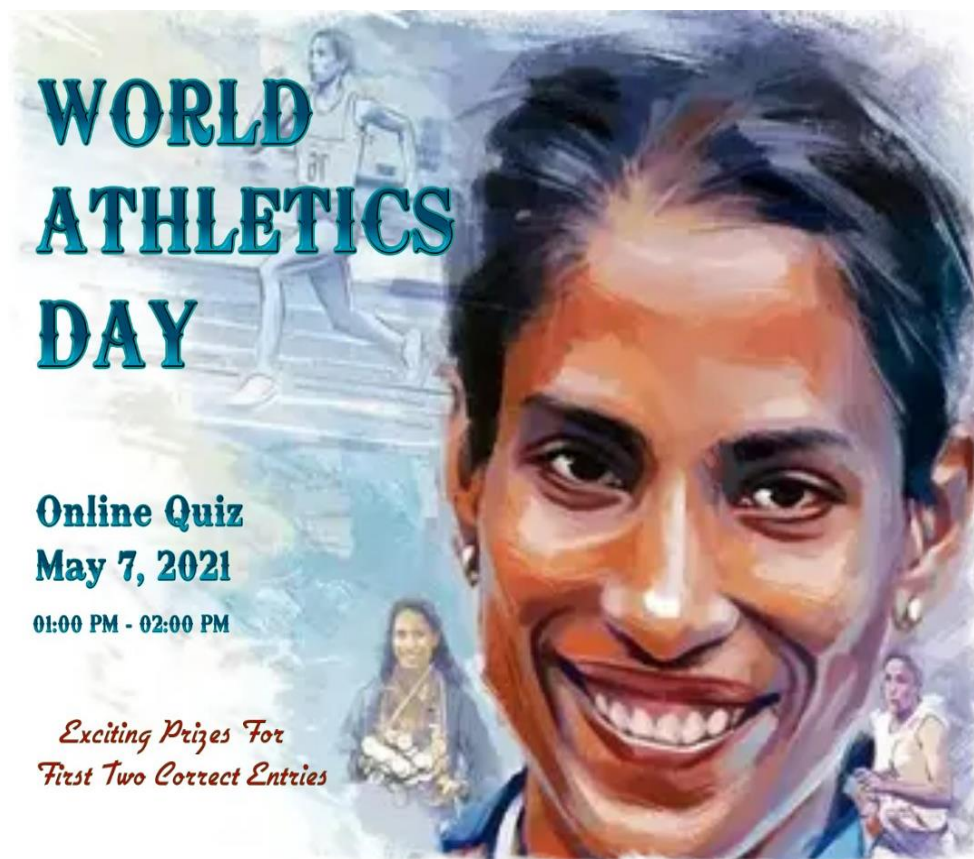

Department of Student Support Services

Intra-ASOL Moot Court Competition - 12th & 13th May 2021



 **ALLIANCE UNIVERSITY**
Private University established in Karnataka State by Act No.34 of year 2010
Recognized by the University Grants Commission (UGC), New Delhi.

INTRA-ASOL MOOT COURT COMPETITION

May 12-13, 2021
10:00 AM ONWARDS
Online

ALLIANCE MOOT COURT COMMITTEE 

Department of Student Support Services

Essay Writing Contest! - 17th May 2021



 **ALLIANCE UNIVERSITY**
Private University established in Karnataka State by Act No.34 of year 2010
Recognized by the University Grants Commission (UGC), New Delhi.

ESSAY WRITING COMPETITION

OPNE FOR ALL

THEME: 75 YEARS OF INDEPENDENCE

Submit your essay at: student.services@alliance.edu.in
Word limit: 300 | Language: English | Submit by: 19-03-2021

Department of Student Support Services

OFFICE OF THE REGISTRAR

The Office of the Registrar is the administrative backbone supporting the academic goals of Alliance University. It is a back office that efficiently supports the front office of academic instruction and allied activities at the university.

The Office develops and maintains accurate and timely processes that directly affect the students and faculty. It also enhances, adheres, and enforces Alliance Universities academic policies. It upholds the integrity of the institution by maintaining the accuracy of every student's academic record with the assurance that they receive exemplary customer service.

NEW INITIATIVES AT THE OFFICE OF THE REGISTRAR.

Several new initiatives have been attempted at the Office of the Registrar to improve the working and operating efficiency in a document driven administrative system. The details are as under-

- **Digital Records Management** has been adopted to help in the transition to a “Less paper” office where all students data can be stored in an electronic format thus ensuring safe storage in minimal space. Converting a ‘paper-based’ process into a ‘paper-less’ is an attainable accomplishment that can digitization has been implemented by way of-
 - Virtual uploading of academic documents
 - Virtual verification of student credentials-contactless procedure
 - Processing and storing student records in digital format using ERP
 - Automation of No-Due certificate application & issue
 - Online application for transfer & Migration certificate

The above has a physical backup too as it is a phase of trial and transition.

- **Automatic generation of certificates** with relevant numbers -Transfer Certificate/Migration Certificate
- **Auto generation of student Permanent Registration Numbers**
- **Process flowcharting/Process mapping**

The Office of the Registrar has also initiated the development of Process Maps for all its operations. a graphical tool will ensure that administrative support staff and the staff have more control over their work. This defines timelines, responsibility, and authority for all processes. Advantages also include better communication, analysis, and adequate documentation.

INITIATIVES DURING COVID 19 PANDEMIC AT ALLIANCE UNIVERSITY

Alliance University is committed to excellence in education and Research while ensuring safety and well-being of all its students, faculty, staff and its extended community. This was exhibited in an exemplary manner during the Pandemic.

‘Disruption often creates opportunities’ and true to this saying, the Think Tank at Alliance University brainstormed and developed new paradigms for the academic year 2021.

Alliance University set up a COVID CARE TEAM – **“Alliance Cares’**. The Alliance COVID CARE team helped with the following-

- Latest information on COVID related guidelines
- Latest information on availability of COVID medicines, oxygen supply, oxygen beds, ICU etc.
- Information on Plasma donors within and outside the Alliance Community.
- Information on verified testing laboratories and hospitals across Bangalore

The Alliance Cares Team comprised the following members-

Mr. Prakash Budur Pro-Vice Chancellor-Banking, Finance, Development & New initiatives	Team Lead
Mr. Santosh Kawari Chief Information Officer	Member
Dr. Sunil Kumar Professor & Deputy Registrar-Examination &Evaluation	Member
Dr. Sanjeev Padashetty Professor & Deputy Registrar-Administration	Member
Mr. Rama Rao K Manager- Human Resource	Member

CAMPUS PREPAREDNESS

The following measures are adopted to ensure a safe, hygienic, and well-maintained campus

- Based on Karnataka State Guidelines, the campus remained closed until communication by the government, ensuring safety and well-being of all its stakeholders.
- The university workforce transitioned to work- from-home. Team Infrastructure Technology Services (ITS) and certain support staff, have restricted access on a need basis.
- University operations continue to be functional, and all services are made available virtually – timely conduct of classes and examinations; access to online resources; group discussions with faculty members to handle student queries; peer discussions to facilitate better learning – ensuring academic delivery of services remain uninterrupted.
- Resident students have access to round-the-clock internet connectivity, security services, food court, ATM and laundry.
- The halls of residence, food court and university premises are sanitized regularly.
- Resident doctor and ambulance service on campus is available in case of need.
- A quarantine facility has been organized within the University to provide isolation, in case of need.
- Visitors to the university and halls of residences are prohibited until further notice.
- Resident students are encouraged not to move outside the campus unless it is an exigency.

STUDENT INTAKE & SAFETY

The entire process of student intake was remodelled into an online system. Virtual onboarding and document verification methods were developed to suit the requirements of the pandemic protocol.

Academic digitisation helped in-

- Teach & Learn
- Research & Engage
- Connect And Socialize

Details of vaccination status of all University employees and Students is periodically sought through online mode and compiled for verification and records.

Further to the relaxation of lockdown restrictions as per the guidelines from the governmental authorities, the University resumed its on-campus academic activities with health and safety as its utmost priority

All University Facilities including Vehicles entering the University premises were sanitised regularly. Hand sanitising stations at vantage locations added to the sterile environment.

Regularly sanitised and safe residential facilities were thrown open to the vaccinated students such that they can enjoy the campus infrastructure.

COVID testing facilities and isolation facilities were also provided in case any student was a COVID suspect.

Periodical vaccination drives were conducted at the University for both Employees and students to ensure 100% vaccinated campus.

VACCINATION DRIVES AT ALLIANCE UNIVERSITY

In accordance with directives from the Ministry of Health and Welfare and with an aim to vaccinate the entire country's population this year, the University organized vaccination drives for all its staff, students, and faculty at periodic intervals. All drives were conducted, keeping in mind social distancing norms and other safety advisories issued by the Government of India /State Government for prevention of COVID Pandemic.

Vaccination drives were conducted on the below dates

- 06th June,2021
- 02nd July,2021
- 04th August,2021
- 17th September 2021

VACCINATION DRIVE 1

Alliance University organised a vaccination drive on **June 6,2021** from 9.00am -6.00pm for its faculty and staff in collaboration with Apollo Spectra Hospital, Koramangala.

The primary objective of this drive at the institutional level was to assist the faculty and staff along with their family to complete their vaccination in a timely manner, enabling health & safety during the pandemic.

VACCINATION DRIVE 2

Further to the relaxation of the lockdown restrictions as per the guidelines from the government authorities, the University in collaboration with the Health Department, Government of Karnataka held a vaccination drive (COVAXIN) on **July 2,2021** at the Central campus.

VACCINATION DRIVE 3

On receiving the directive for reopening of all campuses of the University for in -person academic activities, the second vaccination camp for COVAXIN was held on **August 4,2021** in collaboration with the Health Department, Government of Karnataka.

VACCINATION DRIVE 4

This was followed by a drive on **September 17,2021** in collaboration with the Health Department, Government of Karnataka where COVISHIELD vaccines were administered.

The activity centre was used as the vaccination centre. Areas were demarcated for the following activities:

- Reception & Registration
- Waiting room
- Vaccination room
- Post Vaccination convalescence
- Medicine dispersal desk.



Waiting Area



Registration Desk



The SOP and guidelines for safety during the pandemic was developed and shared with the students, faculty, staff and others.

CONVOCATION 2021

Alliance University hosted its Convocation on March 27, 2021 in the virtual mode. Graduating students from all across the world witnessed a well-orchestrated convocation ceremony telecasted from the university campus in Bengaluru. The convocation ceremony saw convergence of intellectuals sharing their vision about the map laid by Honourable Prime Minister Shri Narendra Modi on the future of education through the National Education Policy that highlights the growing need of interdisciplinary education and research that aims to create a self-reliant India and a better society at large.

The virtual convocation ceremony was graced by the Chief Guest and Pro-Visitor of Alliance University, Dr. C.N. Ashwathnarayan, Deputy Chief Minister & Minister for Higher Education; IT & BT; and Science & Technology, Government of Karnataka. Shri Nikhil Kamath, Co-founder and Chief Investment Officer, True Beacon and Zerodha; and Shri D.N. Nanjunda Reddy, Senior Advocate, High Court of Karnataka brought honour to the ceremony as the Guests of Honour.

Alliance University conferred The Doctor of Philosophy (Ph.D), Master of Business Administration (MBA), Master of Commerce(M.Com), Master of Business Administration in Business Analytics (MBA-BA), Master of Fine Arts (MFA), Master of Law (LLM), Post Graduate Diploma in Management (PGDM), Executive Master of Business Administration (EMBA), Executive Post Graduate Diploma in Management (EPGDM), Bachelor of Business Management(BBM), Bachelor of Business Administration (BBA), Bachelor of Commerce (Honors), Bachelor of Technology (B.Tech), Bachelor of Arts Bachelor of Laws (Honors) (BALLB), Bachelor of Business Administration Bachelor of Laws (Honors) (BBALLB), Diploma in Business Management, Diploma in Bharatanatyam, Diploma in Kuchipudi, Diploma in Carnatic Vocal, Certificate in Bharatanatyam, Certificate in Kuchipudi, Degrees, Diplomas and Certificates as well as medals of honor and merit certificates on the graduates of Alliance School of Business, Alliance School of Law, Alliance College of Engineering and Design, Alliance Ascent College and Department of Performing Arts in the gracious presence of Prof. Premanand Shetty, Chancellor, Alliance University; Mr. Abhay G. Chebbi, Pro Chancellor, Alliance University; Dr. Anubha Singh, Vice Chancellor, Alliance University; senior administrators; distinguished guests; faculty members and staff members.

The convocation ceremony of Alliance University saw graduation of 4,698 students of which 3,398 received degrees; 1281 received diplomas; and 19 received doctoral degrees. This also included award of medals and merit certificates to 273 rank holders.



Leadership and Faculty at Convocation 2021



Academic procession



Academic procession



Academic procession



Dignitaries on the dais



Lighting of the Lamp ceremony



Convocation address by Dr. C. N. Ashwathnarayan, Deputy Chief Minister & Minister for Higher Education; IT & BT; and Science & Technology, Government of Karnataka

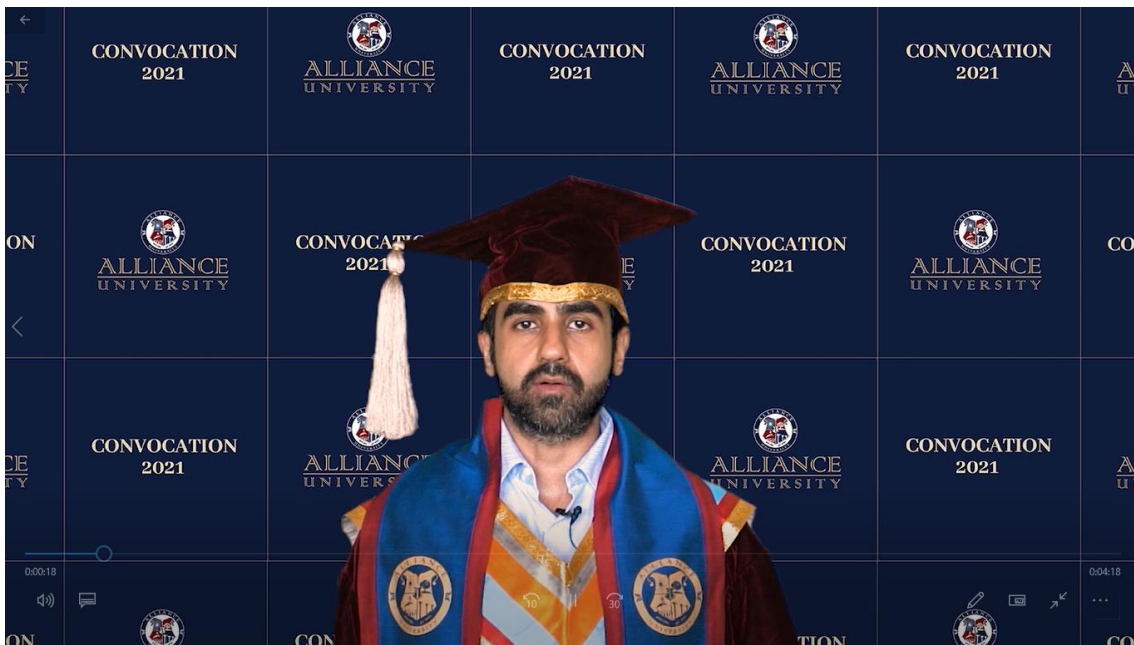

Co-Founder and Chief Investment Officer of True Beacon and Zerodha, Shri Nikhil Kamath Addressing Graduating Students

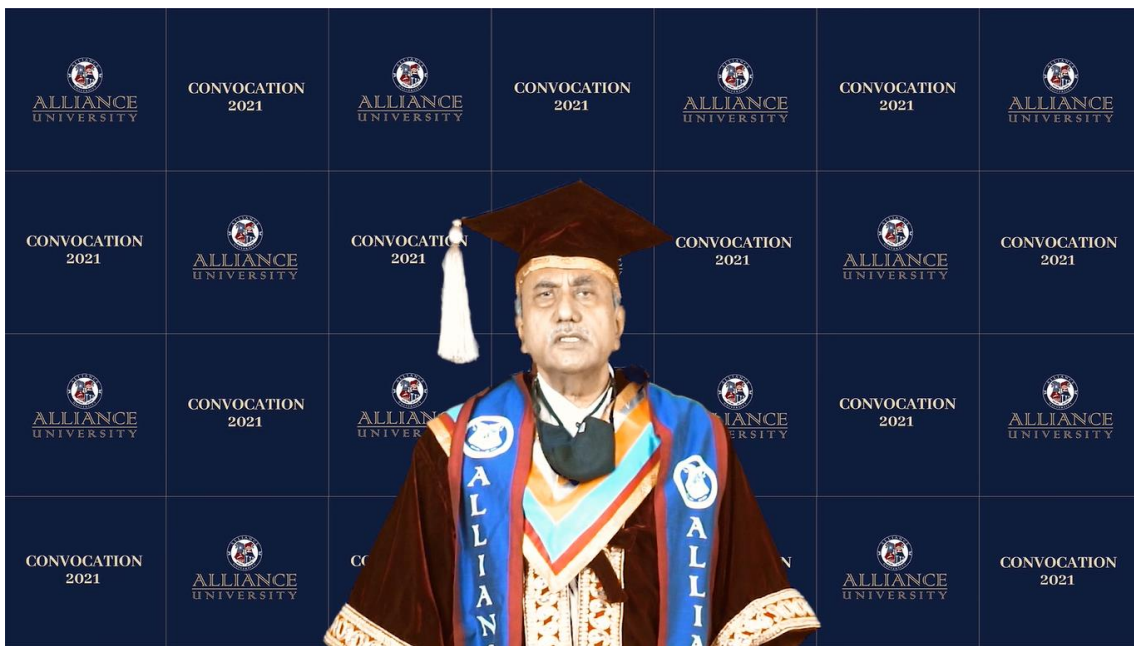

Senior Advocate Shri D.N. Nanjunda Reddy, Addressing Graduating Students



The Chancellor Prof. Premanand Shetty declares the Convocation open



Convocation address by Mr. Abhay G. Chebbi, Pro Chancellor, Alliance University



Convocation address by Dr. Anubha Singh, Vice Chancellor, Alliance University.



Convocation address by Dr. Nivedita Mishra, Registrar, Alliance University

ACADEMIC UNITS

SCHOOL OF BUSINESS

Alliance School of Business, one of the main support pillars of this University, has carved a niche for itself among the best B-Schools in the country, having been ranked consistently among the top B-Schools and for being the first Indian B-School to be accredited by the International Assembly for Collegiate Business Education (IACBE), USA. This accreditation means that the B-School has been recognized as among the very few to have international recognition of a high order and consequently adding value to its degree.

Quality Policy

Alliance School of Business, Alliance University is committed to promote and support effective learning and teaching. The School will contribute to the development of a knowledge society through equitable access and broadening participation in higher education.

- Alliance School of Business would select meritorious students who have a consistent academic record
- The School will have knowledge delivery systems through a combination of academic achievers and industry professionals as faculty
- The knowledge delivery process and content will be reviewed periodically to meet the current and future industry needs
- At least 5 percent of the graduates will be developed as entrepreneurs

The mission rests on six pillars

- Student centeredness
- Excellence in teaching
- Scholarly and application-oriented research
- Contemporary and meaningful executive education and development
- Global focus and cross-cultural sensitivity
- Outreach activities that serve society and enhance the quality of life

Faculty Awards, Accolades, Recognition

Name(s)	Topic/Title	Organization	Date/ Month/ Year
Dr. Pratima Verma	Faculty award	KTK Outstanding achievers and education foundation	June 27, 2021
Dr. Subhradev Sen	Best Theoretical Research Paper Award	Department of Statistics, Pondicherry University, India.	December 22, 2020
Dr. Radhakrishna G S	Impact of Financial Variables and Corporate Governance Variables on Loan Loss Provision in Indian Public and Private Sector Banks	NIT Trichy	April 30, 2021
Dr. Sunil Kumar	SAS Eminent Fellow Membership (SEFM)	Scholars Academic & Scientific Society India	February 12, 2021
Dr. Sunil Kumar	Dynamic Leader of the Year Award	MSME Development Institute, Govt. of India & Global Triumph Foundation in Global Startup Summit & Awards	January 30, 2021
Dr. Sunil Kumar	Best Faculty among Business Schools Award	Global Triumph Foundation in GTF World Business Summit 2020	November 21, 2020

Research Publication: Journals

Name(s)	Topic/Title	Name of the Publisher/Journal	Month & Year
Dr Sajan Mathew	Transforming Marketing Using Neuroscience and Neurotechnology	International Research Journal of Modernization in Engineering Technology and Science	May/2021
Dr Sajan Mathew	The Need for Information System in Hospitals	International Journal of All Research Education and Scientific Methods	May -2021
Dr Sajan Mathew	The importance of information in Supply Chain Management	International Journal of Advance Research, Ideas and Innovations in Technology	May 2021
Dr Sajan Mathew	The need for digital transformation in business	International Journal of Advance Research, Ideas and Innovations in Technology	May/2021
Ms. Himadri Srivastava, Dr. Priya Soloman and Dr. Satyendra Pratap Singh	Impact of Exchange Rate and Trade Openness on Stocks of BSE Sensex in Long Run and Short Run: An ARDL Bounds Testing Approach	-	Dec/2020
Ms. Himadri Srivastava, Dr. Priya Soloman and Dr. Satyendra Pratap Singh	Impact of Real Exchange Rate and Trade Openness on Sectoral Indices of Banking and Auto Industry: An Analysis of Vecm Based Granger Causality Test	-	Apr/2021
M.Prasanna Mohan Raj	Personality profiling of potential car buyers - Cluster Analysis Approach	Journal: The Empirical Economics Letters (ABDC indexed)	August 2021

Name(s)	Topic/Title	Name of the Publisher/Journal	Month & Year
Ms. Nikhitha MH and Dr. Satyendra P. Singh	A Study on Risk and Return Analysis of Prominent Stocks of Automobile and Pharmaceutical Sectors in India	-	July-December 2020
Sukanya Kundu, Subhradev Sen, Prof. Suman Kalyan Ghosh	India's District Information System for Education data to map Sustainable Development Goal 4 of UNESCO – A Descriptive Analytics	Alliance Management Studies International Conference 2021 Social Challenges & Business Responses, Alliance University	January, 2021
Dr. Akshay Dhume	Farmers' agitation: A Leaf from History	Deccan Herald	March 31, 2021
Dr. Mrinmoy Bhattacharjee	Apple is spearheading the revival in personal computers	Business Insider India	June 29, 2021
Dr. Mrinmoy Bhattacharjee	Customer loyalty has a new antecedent-Social Justice	The Strategy Story	June 26, 2021
Dr. Mrinmoy Bhattacharjee	How to create a self-sustaining customer experience system	The Strategy Story	November 23, 2020
Dr. Mrinmoy Bhattacharjee	Case- A Health Insurance Company with a purpose to make people healthier- Discovery Health	The Strategy Story	January 21, 2021
Dr. Mrinmoy Bhattacharjee	Book Review "The infinite game" by Simon Sinek	Marketing Mastermind, ICFAI University Press	June 2020
Dr. Mrinmoy Bhattacharjee	Case- Market expansion strategy of Guibolso to serve the unserved	The Strategy Story	June 2021

Name(s)	Topic/Title	Name of the Publisher/Journal	Month & Year
Ms. Nikhitha MH and Dr. Satyendra P. Singh	A Study on Risk and Return Analysis of Prominent Stocks of Banking, FMCG and IT Sector	-	April-September 2020
Dr. Sunil Kumar	A Study on India's New Generation Women Entrepreneurs: Propelling Community Empowerment through Transformative Relationships	IOSR Journal of Business and Management.	Sep/2020
Dr. Sunil Kumar	A Case of India. Impact of COVID-19 on Indian Economy. A Macroeconomic Assessment	Wesleyan Journal of Research	Sep/2020
Dr. Sunil Kumar	Testifying the Mediating Role of Innovation in Knowledge Management and Organisational Performance Relationship.	International Journal of Knowledge Management and Practices	Jun/2021
Dr. Varadaraj A	Stress Management of college teachers with reference to Chennai District	Ciencia and Engenharia/ Science and Engineering Journal, Pp-66-80 May 2021. Volume 68 Issue 5	May/2021
Dr. Satyendra P. Singh	Investors' Behaviour During Covid-19 Crisis: A Study of Mutual Fund Investors in Bangalore City	-	Apr/2021

Name(s)	Topic/Title	Name of the Publisher/Journal	Month & Year
Dr. Joseph Roche	Organizational Image and Attractiveness in the context of Recruitment: A conceptual review	International Journal of Advanced Scientific Research and Management 5(10):24	Oct/2020
Dr. Satyendra P. Singh	Study on Investment Behaviour of Mutual Fund Investors of Noida & Greater Noida During Covid-19 Crisis	-	Jul/2020
Tanu Jain and Dr. Satyendra P. Singh	Impact of Domestic Institutional Investors on Foreign Institutional Investors in India: An Analysis	-	Jul/2020
Dr.Satish Menon	Security Challenges Faced by IOT (Internet of Things) in the Present Age of Technology	Recent Developments in Computing, Electronics and Mechanical Sciences- Anvi Books and Publishers Chapter 7	Jul/2020
Dr.Satish Menon	Impact of Digitization On CRM for B2b Firms	International Journal of Advance Science and Technology.Vol. 29, No. 10S, (2020), pp. 7144-7153. Page Number 7144 - 7154	Jun/2020

ASCENT COLLEGE

Alliance Ascent College, a constituent college of Alliance University, provides a high quality academic environment with dedicated teaching staff and recognized strength in applied research underpinned by an outstanding support of the university.

Alliance Ascent College prides itself on rigorous and relevant curriculum designed to train young professionals to be responsive to the demands of society in a dynamic milieu.

Ascent College Activities



Research Publication - Journals

Name(s)	Topic/Title	Name of the Publisher/Journal	Month & Year
Prof. Mohana Sundaram k	SME quality standards in India - An overview	International journal of innovative research in Technology, vol 7, Issue 11: ISSN: 2349-6002, pp. 672-674	April 2021
Prof. Mohana Sundaram K	SME quality standards in India - An overview	International journal of innovative research in Technology, vol 7, Issue 11: ISSN: 2349-6002, pp. 672-674	April- 2021
Dr. Varadaraj A	"A Study on Contribution of Digital Human Resource Management towards Organizational Performance	International Journal of Management Science and Business	Jul/2021
Dr. Varadaraj A	Critically analyzing the management process in the service sector through virtual workflow	Q2 SCOPUS JOURNAL, Tianjin Daxue Xuebao (Ziran Kexue yu Gongcheng Jishu Ban)/ Journal of Tianjin University Science and Technology ISSN (Online): 0493-2137 E-Publication: Online Open Access Vol:54 Issue:	Jul/2021
S. Ananth, Varadaraj.A	Critically Analyzing The Management Process In The Service Sector Through Virtual Workflow	Tianjin Daxue Xuebao (Ziran Kexue yu Gongcheng Jishu Ban) / Journal of Tianjin University Science and Technology	Jul/2021

ALLIANCE COLLEGE OF ENGINEERING & DESIGN

The Alliance College of Engineering and Design has been built on a strong foundation of achieving technological development through a curriculum that places a high emphasis on the design aspects of engineering by developing design professionals who are passionate and creative problem-solvers, and who possess strong multi-disciplinary fundamentals that are combined with a keen sense of aesthetics. Real-world, industry-driven internships and project work; centers of excellence and incubation for cutting-edge research and development; learning outcomes aligned with the criteria outlined by the Accreditation Board for Engineering and Technology (ABET), USA—the Alliance College of Engineering and Design provides unparalleled opportunities for graduates to pursue technological education with passion and confidence



AICTE Training and Learning Faculty Development Programme

The Department of Aerospace Engineering, Alliance College of Engineering and Design, made a remarkable contribution to the University in organizing the first AICTE Sponsored ATAL 5-Day Online FDP on “Advancements in Computational Fluid Dynamics using Fluidyn” from 7th of June to 11th of June 2021, in collaboration with Fluidyn Consultancy Private Limited. The achievement was made possible by the tremendous initiative and excellent teamwork by the department and renowned speakers from IISc, various IITs, NITs and other reputed organizations with the technical talks and hands-on training.

Name of the ATAL FDP Coordinator: Prof. Gisa G S

Name of the Co-ordinators: Prof. Hariprasad Thimmegowda &
Prof. Yadu Krishnan S

Total number of participants
from across the country: 200

Number of participants
successfully completed the FDP: 156

Date of Application Submitted: March 5, 2021

Application Number: 1614316667

Date of Acceptance of FDP: May 3, 2021

Grant Received from AICTE: ₹93,000/-

Technical-Talk

Topic: Digital Design and its application in EDA industry

Speaker: Mr. Ashutosh Gupta
Digital Verification Engineer in TCS, Consulting EDA Tool Projects

Organised by: Department of Electronics and Communication Engineering

Technical talk was conducted on 27th Feb 2021 to understand the essence of digital design concepts and its implementation in EDA/VLSI industries. This talk was organized for all graduate students and research scholars of ECE department.

There are plenty of job opportunities to work with VLSI industries in India or abroad. Students are needed to apply the learnings on EDA tools to fill the gap between academic studies and industry readiness. This technical talk also guided the students to be clear with basics and to be exposed to one of the EDA tools remarkably. In addition to this, the resource person also answered some queries regarding the skills needed to get the job in VLSI industry.

Research / Publications / Journals

Name of author	Title of Work	Journal / Publisher Name	Published Year
Prof. Hariprasad Thimmegowda & Prof. Yadu Krishnan S	Computational and Experimental Study on Flow Quality of Open-Loop Low-Speed Wind Tunnel	International Journal of Engineering Research & Technology (IJERT)	February 2, 2021
Prof. Gisa G S& Prof. Yadu Krishnan S	A Study on the Effect of J2 Perturbation on Optimum Delta-V for Collision Avoidance Maneuver	International Journal of Engineering Research & Technology (IJERT)	October, 2020
Prof. Yadu Krishnan S	A Process and System for Index Based Data Analysis for Correlating Physical Properties of Anti-Cancer Chemical Compound on A Client Computing Device	Patent	December 6, 2020
Pavan Kalyan.M, Shylendra R,Asha Rani.N.R	Evaluation of wastewater treatment using Lemon peels and tulsi leaf powders as Natural coagulants	International Journal of New Innovations in Engineering and Technology	Jun-2021
Sri Durga Parvatham, Asha Rani.N. R	Evaluation of Wastewater Treatment Using Banana Fruit Peel Powder as Natural Coagulant	International Research Journal of Innovations in Engineering and Technology (IRJIET)	Jun-2021
Raksha. A , Asha Rani. N. R	Treatment of Wastewater Using Orange Peel Powder as Coagulant	International Journal of Scientific Engineering and Applied Science	Jun-2021

Name of author	Title of Work	Journal / Publisher Name	Published Year
Sankeeth.K. V , Asha Rani.N. R	Use of Neem Leaf Powder as Natural Coagulant to Treat Industrial Wastewater	International Journal of Innovative Research in Technology	Jun-2021
Irfan Shariff.M , Asha Rani.N. R	Evaluation of wastewater Treatment using Hyacinth bean peel powder as Natural coagulant	International Journal of Innovative Research in Technology	Jun-2021
Upadhyay shreya Rajendra , Asha Rani. N. R	Wastewater Treatment Using Banana Pith Powder	International Journal of Innovative Science, Engineering & Technology	May-2021
Asha Rani. N. R	Removal of turbidity by using natural coagulants such as magnifera indica and moringa olifera seed powder	International Journal of Engineering Research	Jan-2021
M W Hussain and D S Roy	A Counter based Profiling Scheme for Improving Locality through Data & Reducer Placement	Advances in Machine Learning for Big Data Analysis- Springer	June 2021
Dr. Shekhar R	Applications of Multidimensional Databases of Psychological Study Based on Olap- Based Model	IJAST, Volume 29 ISSN: 2005-4238	September 2020
Dr. Shekhar R	Design Of a Flip-Flop to provide Low Latency and to Avoid Redundancy for Low Power Applications in ICICEE-2020	International Journal of Advanced Science, and technology ISSN: 2005-4238	July 2020

Name of author	Title of Work	Journal / Publisher Name	Published Year
Dr. Shekhar R	Model Of a Flip-Flop to provide Low Latency and to Avoid Redundancy for Low Power Applications	International Journal of Advanced Science, and technology ISSN: 2005-4238	July 2020
Dr Selvarani R	Review on deep learning approach for brain tumor glioma analysis	European Journal of Molecular & Clinical Medicine	Jan 2021
Dr. Ramalakshmi K	Analysis of DNA Sequence Classification Using CNN and Hybrid Models	Computational and Mathematical Methods in Medicine	July 2021
Dr.K.Ramalakshmi	Literature Review of Disease Detection in Tomato Leaf using Deep Learning Techniques	International Conference on Advanced Computing and Communication Systems, ICACCS-2021	March 2021
Dr. R. Selvarani	Review on Deep learning approach for brain tumour glioma analysis	Journal of Information Technology in Industry Networking Vol. 9, No.1	June 2021
Prof. Radha R	A Survey on Autonomic Computing: Inspired by the Human Body's Autonomic Nervous System	International Journal on Computer Science and Mobile Computing for the publication of research work	March 2021

Name of author	Title of Work	Journal / Publisher Name	Published Year
Prof. Radha R	A Survey on Resale of Automobiles Using Emerging Technology: Blockchain	International Journal on Computer Science and Mobile Computing for the publication of research work	March 2021
Dr. Ramalakshmi. K	A Deep Learning CNN model for Genome Sequence Classification: Intelligent Computing Applications for COVID-19	Taylor and Francis	June 2021
Dr. Chitra Kiran. N	Performance Enhancement of Futuristic (5g) Communication System By Generating (Downlink) Waveform	International Journal of Advanced Research in Engineering and Technology (IJARET)	Nov 2020
Dr. Sridhar T	Design of a flip-flop to provide low latency and to avoid redundancy for low power applications	International Journal of Advanced Science and Technology	Dec 2020
H. Aireddy, S. Guchhait and A. K. Das	Development of liquid nitrogen flow cryostat for low-temperature measurement in cantilever beam magnetometer	India International Science Festival (IISF): Young Scientist Conference (YSC)-2020, India	Nov 2020
S. Guchhait, H. Aireddy and A. K. Das	Room temperature direction dependence of magnetostrictive strain on magnetic field in polycrystalline CoFe ₂ O ₄ film	India International Science Festival (IISF): Young Scientist Conference (YSC)-2020, India	Nov 2020

Name of author	Title of Work	Journal / Publisher Name	Published Year
Raj, Saurav, Sheila Mahapatra, Chandan Kumar Shiva, and Biplab Bhattacharyya	Implementation and Optimal Sizing of TCSC for the Solution of Reactive Power Planning Problem Using Quasi-Oppositional Salp Swarm Algorithm	International Journal of Energy Optimization and Engineering (IJEEO) 10, no. 2 (2021): 74-103	April 2021
Shiva C.K., Vedik B., Kumar R., Mahapatra S., Raj S.	Impacts of Computational Techniques for Wireless Sensor Networks. In: Das S.K., Dao TP., Perumal T. (eds) Nature-Inspired Computing for Smart Application Design	Springer Tracts in Nature-Inspired Computing. Springer,	Jan 2021
Mohan Krishna. S, Febin Daya. J.L, Umashankar Subramaniam, Freede Blaabjerg, Rajvikram Madurai Elavarasan, Shaifulla G.M., Irfan Khan, Sanjeevikumar Padmanaban	An Improved Sliding Mode Disturbance Observer for Sensorless Induction Motor Drive used in Electric Vehicles in a New Real-time PIL Test Bench”, Energies	MDPI	Aug 2020
John Lionel, Febin Daya, Jayan, Jestin, Srinivasan, Mohan Krishna and Prabhakaran, Prajof	DC-link current based position estimation and speed sensorless control of a BLDC motor used for electric vehicle applications	" International Journal of Emerging Electric Power Systems, vol. 22, no. 3, 2021, pp. 269-284	Feb 2021
M. Krishna S and T. Perumal	Making Buildings Smarter and Energy-Efficient—Using the Internet of Things Platform	IEEE Consumer Electronics Magazine, vol. 10, no. 3, pp. 34-41	1 May 2021

Name of author	Title of Work	Journal / Publisher Name	Published Year
Daya John Lionel, Febin, Dias, Jacintha, Krishna Srinivasan, Mohan, Parandhaman, Balamurugan and Prabhakaran, Prajof	A novel non-isolated dual-input DC-DC boost converter for hybrid electric vehicle application	International Journal of Emerging Electric Power Systems, vol. 22, no. 2, 2021, pp. 191-204	Feb 2021
M.Badi, M. Singh	A Passive Filter with SVC Configuration for VAR Control and Harmonic Compensation	International Journal of Innovations in Engineering and Technology (IJJET) Volume no 19, Issue no (1), 30-40	April 2021
Shant Kumar Biradar, M. Badi	Analysing Efficiency and Effectiveness of Clap Switch Mechanism	Journal of Recent Trends in Electrical Power System, Volume no 4, Issue no (01), 1-3.	April 2021
Jayanth Babu C, Badi Manjulata. Swetha S.G.	Review of Wireless Power Transmission Volume no-40, Issue (03),3182-3188	Studies in Indian Place Names	April 2020
Swetha Shekarappa G, Sheila Mahapatra, Selvarani R	Impact of Distributed generation on Distribution Network- A rural case study	SEYBOLD Report Journal" Volume 15 - Issue 9	Sep 2020

Name of author	Title of Work	Journal / Publisher Name	Published Year
Jayanth Babu C, Badi Manjulata. Swetha Shekarappa. G	Review of Wireless Power Transmission	Studies in Indian Place Names, Volume no-40, Issue (03)	July 2020
Sheldon Williamson, Umashankar Subramaniam, Mohan Krishna S (ed.)	(Book publications) Electric Vehicles and the Future of Energy Efficient Transportation	IGI Global Publishers	April 2021
G. D. Deepak, N. K. Joshi, and R. Prakash	Modal analysis of dielectric barrier discharge-based argon cold plasma jet	Laser and Particle Beams vol. 38, no. 4, pp. 229–238	Oct 2020
Mathew Chacko, Atul	Cyber-Physical Quality Systems in Manufacturing	Turkish Journal of Computer and Mathematics Education pg. Vol.12 No.2 no. 2006-2018	April 2021
Dr. Rathnakar Achary	Cryptography and Network Security Book	New Age International Private Ltd., India	Oct 2020
Dr. Rathnakar Achary	Cloud Reliability Engineering: Technologies and Tools	Taylor & Francis US	April 2021
Dr. Rathnakar Achary	Prediction of Congestive Heart Failure (CHF) ECG Data Using Machine Learning Intelligent Data Communication Technologies and Internet of Things	Springer	Jan 2021
Dr. Rathnakar Achary	Internet of things (IOT) security threats on physical layer security	Springer	Jan 2021

Name of author	Title of Work	Journal / Publisher Name	Published Year
Dr. Chetan Shelke	Machine Learning and its Various Algorithms- A Study	JETIR	May 2021
DR. Senbagavalli M.	Artificial Intelligence Based Cooling System for Managing the Energy Efficiency	Patent published	May 2021
Dr. M. Senbagavalli	Automated Meticulous Mitigation of Traffic Congestion In Handling Uninterrupted Travel Of Emergency Vehicles Using RFID And IOT	Patent published	June 2021
Dr M Senbagavalli	Challenges and applications of data analytics in social perspective - Chapter: 9 Social Media Content Analysis: Machine Learning https://www.igi-global.com/chapter/social-media-content-analysis/267245	IGI Global Publisher of Timely Knowledge Inc. USA.	Dec 2020
Dr M Senbagavalli	CNN Model for Image Classification using ResNet	International Journal of Computer Science Engineering and Information Technology Research journal	June 2021
Shanti Konda, Muralidhar Billa, Himanshu Bhatnagar, Shobana	Music Recommendation Based on Child Emotion Through Machine Learning Techniques	LINO Journal, Vol 11, Issue 3, S.No. 56,	14 June 2021

Name of author	Title of Work	Journal / Publisher Name	Published Year
Dr. Shobana Padmanabhan	Knowledge City Technical Campus and ISET Research & HEXAIND Technologies and Services	Conf. Proc	June 2021
Shaik Jahanara, Shobana Padmanabhan	Detecting autism from facial image	Intl. Journal of Advance Research, Ideas and Innovations in Technology,	Mar – Apr 2021.
Kamra, Soumyakshya Das, Shobana Padmanabhan	Detection of COVID 19 through X-rays using CNN and Transfer Learning	Intl, Conf. on Machine Learning Big Data Management Cloud Computing, In Proc. Of Asian Society for Academic Research (ASAR), B'lore	14 Feb 2021
Vasantha Kumari A, Mohd.Umar Peerzade, Subharalina Nayak, Bhagya V, Shobana Padmanabhan	Automatic Facemask Detection using MobileNetV2	International Research Journal of Engineering and Technology (IRJET), Feb 2021	Feb 2021

ALLIANCE SCHOOL OF LAW

Alliance School of Law, Alliance University is approved by the Bar Council of India (BCI), New Delhi. The courses have been carefully crafted and designed to prepare its graduates for rewarding careers in various roles and responsibilities in legal service organizations.

The Alliance School of Law is committed to imparting world-class learning in law practice and governance to its key constituents. To fulfill this objective, the curriculum and teaching pedagogy is designed to prepare its graduates in the domestic, international and comparative law subjects. Graduates from the Alliance School of Law study compulsory subjects and choose from an unparalleled range of elective subjects. In addition to subjects on substantive and procedural law, its attorney-graduates also acquire lawyering skills through practical training activities and clinical, legal programs even while arch and writing skills.



Research /Publications /Journals

Name of author(s)	Title of Work	Journal / Publisher Name	Year of Publication
Abhishek Srivastava	Client management and Client Interaction Model for Law Office	International Journal of Advanced Research, Ideas and Innovations in Technology (IJARIT)	2021
Abhishek Srivastava	Comparative Study of Sports Law in India and France	International Journal for Research in Applied Science and Technology	2021
Neha Purohit	The Trial of Mahatma Gandhi, 1922. chapter in edited book, Revisiting Gandhi by Dr Seema Sharma.	Raj Publishing House, Jaipur	2021
Sonali Karale and Vishal Ranaware	Impact of COVID-19 on Education Sector in India	Sodh Sarita / Sanchar Educational & Research Foundation, Lucknow (U.P.) India	2021
Vishal Ranaware	Notion of Copyright Protection in Open Access Publications and Development of Self-Learning Material	Symbiosis International Research Journal on Online & Distance Learning / Symbiosis Centre for Distance Learning, Pune	2021
Sonali Karale and Vishal Ranaware	Blockchain Technology in Data Privacy: A Bibliometric Analysis	International Journal of Advanced Science and Technology (IJAST) / Science and Engineering Research Support Society	2021
Abhilash Arun Sapre	Anti-terrorism Laws and Human Rights in India: An Appraisal	Journal of Global Research & Analysis Vol.10 Issue 1(ISSN no.- 2278-6775)	2021
Dr. Smita Satapathy	Role of RBI in Credit Control	<i>Pramana Research Journal</i>	

Name of author(s)	Title of Work	Journal / Publisher Name	Year of Publication
Prof. Abhilash Arun Sapre	Non-Refoulment of Refugees in India-A Human rights Perspective	International journal of Law and Social Science (ISSN no.-2454-8553) of Alliance University, Bengaluru.	2021
Prof. Abhilash Arun Sapre	Reproductive rights of women vis-à-vis surrogacy and its Comparison with India, USA and UK	“Lexigentia”- International Law Review of Lloyd Law College, Noida.	2020
Dr. Smita Satapathy, Dr. Madhubrata Mohanty	Punishing the Suicide Survivors- The Justifiability	Indian Journal of Forensic Medicine & Toxicology	2021
Dr. Smita Satapathy, Dr. Arunima Mishra	Right to Life of a Child in India: An Overview	Medico-Legal Update	
Dr. Smita Satapathy, Dr. Madhubrata Mohanty	Role of Mental Health in Understanding and Preventing Suicide	Medico-Legal Update	2021
Dr. Smita Satapathy, Dr. Madhubrata Mohanty	Law Relating to ‘Right to Die’	Journal of Critical Reviews	2021
Dr. Avanish Bhai Patel	Challenges Faced by Older People in a District of Uttar Pradesh: A Qualitative Study	The Journal of Adult Protection	2021
Prof. Barsa Priyadarsinee Sahoo and Dr. Avanish Bhai Patel	Social Stigma in Time of COVID-19 Pandemic: Evidence from India	International Journal of Sociology and Social Policy	2021

Name of author(s)	Title of Work	Journal / Publisher Name	Year of Publication
Dr. Avanish Bhai Patel and Sumant Kumar	A Sociological Study of Suicide during COVID-19 in India	Journal of Mental Health and Social Inclusion	2021
Dr. Avanish Bhai Patel	Psychological Factors of Fear of Crime: An Empirical Study of Older People in Lucknow, India	The Journal of Adult Protection	2020
Dr. Avanish Bhai Patel	Is Mob Lynching a Contemporary Social Problem in India?	International Journal of Criminology and Sociology	2020
Dr. Avanish Bhai Patel	Bharat Me Kisaan Atm Hatya: Bhaugolik Evam Samajik Adhyayan	Samajik Vimarsh	2020
Dr. Avanish Bhai Patel	Crime against Elderly Women in India	Frailty in the Elderly – Understanding and Managing Complexity/London: Intech Open Limited	2021

Faculty Awards, Accolades, Recognition

Faculty Name	Details
Prof. Barsa Priyadarsinee Sahoo	Received “Young Researcher Award 2021” By Institute of Scholars (InSc), Bangalore for the research paper published in International Journal of Sociology and Social Policy titled “Social Stigma in Time of COVID-19 Pandemic: Evidence from India” published in April 2021.

ESTABLISHMENT OF NEW ACADEMIC DEPARTMENTS

The University established new schools and departments in accordance to the growth strategy. All the academic units of the University were broadly classified under three faculties; namely;

- Faculty of Management Studies & Commerce
- Faculty of Science & Technology
- Faculty of Humanities, Liberal Arts & Social Sciences

The move was aligned to the National Education Policy 2020 that emphasizes on holistic education for students. The new schools and departments are:

- Alliance School of Applied Mathematics
- Alliance School of Liberal Arts
- Alliance School of Digital Technology
- Department of Language & Literature
- Department of Economics
- Department of Science

ALLIANCE UNIVERSITY

The University is confederation of Faculties, Schools, Colleges, Departments, and Centres of Excellence

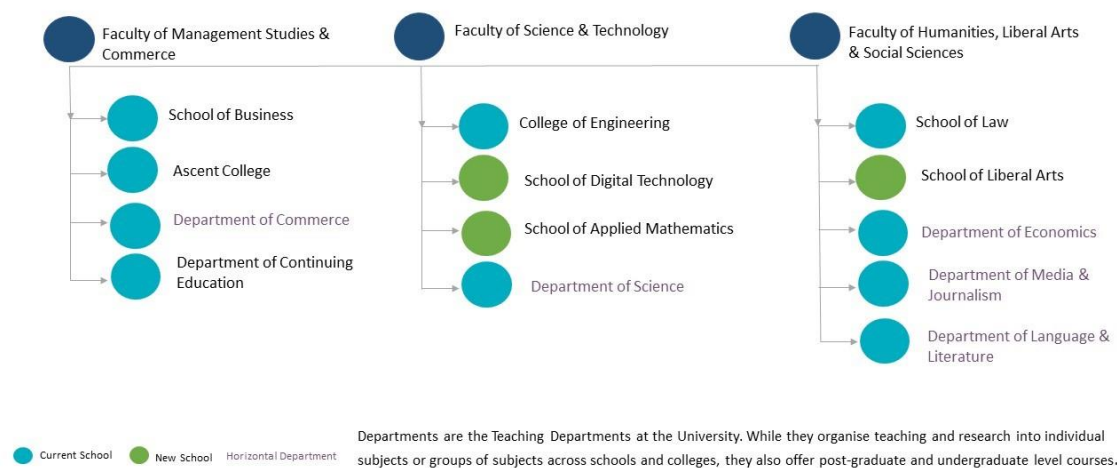

Academic Structing of Alliance University – Jun 28, 2021

Research policy

Alliance University revised its research policy and brought in many salient features to promote and boost research activities.

Research-Centric University

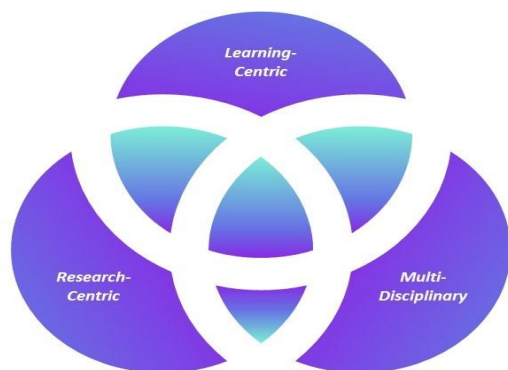

Strategic Priority Actions

A detailed research policy outlining

Faculty of Doctoral Studies and Research

Research Objectives

Research Policy

Evaluation of Research

HRD Scheme for Academic Enrichment

Policy for the Sponsored Research

Consulting and Other Outside Professional Activities

Research incentives

Research Policy at Alliance University

INFRASTRUCTURE



Administrative Block



Activity Center



Learning Center



Seminar Hall



Central Library



Moot Court



Labs @ Alliance University

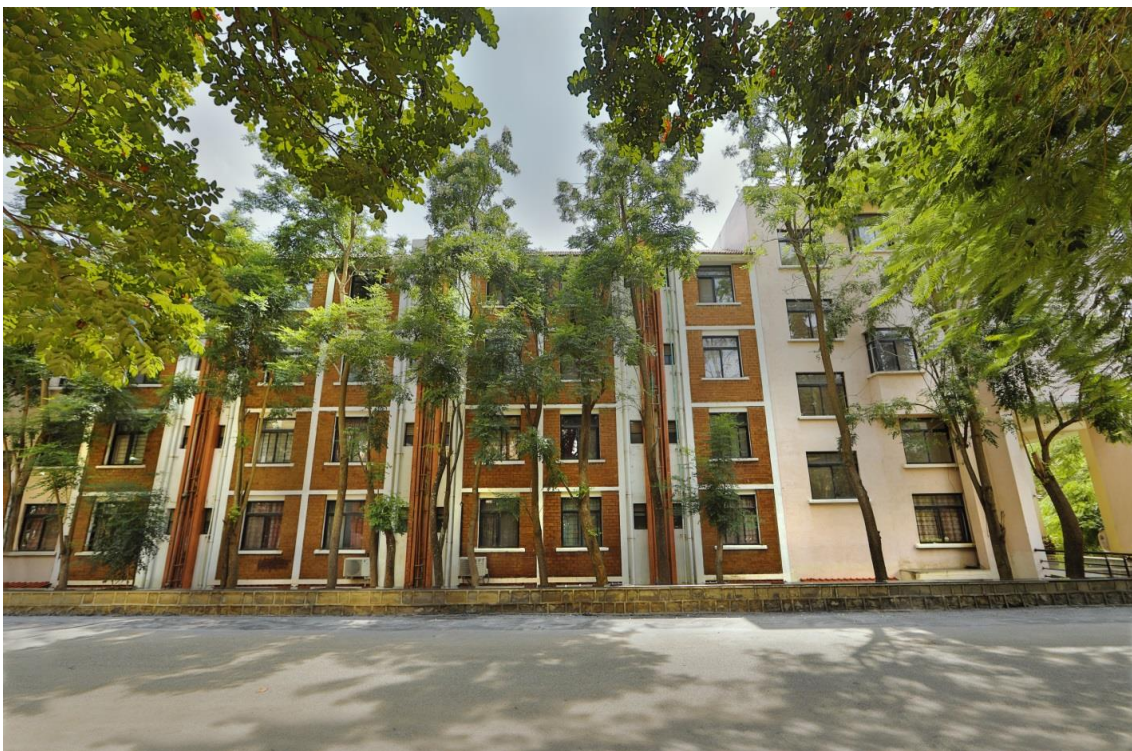

Halls of Residence



Food Court



Classrooms



ALLIANCE UNIVERSITY

*Private University established in Karnataka State by Act No.34 of year 2010
Recognized by the University Grants Commission (UGC), New Delhi*

BENGALURU